



**Avaya 3740/ 3745/ 3749 DECT  
Telephones**  
connected to  
Avaya Aura™ Communication Manager  
and IP Office

User Guide

21-603690  
02/2016  
Issue 5.0

#### Notice

While reasonable efforts have been made to ensure that the information in this document is complete and accurate at the time of printing, Avaya assumes no liability for any errors. Avaya reserves the right to make changes and corrections to the information in this document without the obligation to notify any person or organization of such changes.

#### Documentation disclaimer

"Documentation" means information published by Avaya in varying mediums which may include product information, operating instructions and performance specifications that Avaya may generally make available to users of its products and Hosted Services. Documentation does not include marketing materials. Avaya shall not be responsible for any modifications, additions, or deletions to the original published version of documentation unless such modifications, additions, or deletions were performed by Avaya. End User agrees to indemnify and hold harmless Avaya, Avaya's agents, servants and employees against all claims, lawsuits, demands and judgments arising out of, or in connection with, subsequent modifications, additions or deletions to this documentation, to the extent made by End User.

#### Link disclaimer

Avaya is not responsible for the contents or reliability of any linked websites referenced within this site or documentation provided by Avaya. Avaya is not responsible for the accuracy of any information, statement or content provided on these sites and does not necessarily endorse the products, services, or information described or offered within them. Avaya does not guarantee that these links will work all the time and has no control over the availability of the linked pages.

#### Warranty

Avaya provides a limited warranty on Avaya hardware and software. Refer to your sales agreement to establish the terms of the limited warranty. In addition, Avaya's standard warranty language, as well as information regarding support for this product while under warranty is available to Avaya customers and other parties through the Avaya Support website:

<https://support.avaya.com/helpcenter/getGenericDetails?detailId=C20091120112456651010> under the link "Warranty & Product Lifecycle" or such successor site as designated by Avaya. Please note that if You acquired the product(s) from an authorized Avaya Channel Partner outside of the United States and Canada, the warranty is provided to You by said Avaya Channel Partner and not by Avaya.

"Hosted Service" means a hosted service subscription that You acquire from either Avaya or an authorized Avaya Channel Partner (as applicable) and which is described further in Hosted SAS or other service description documentation regarding the applicable hosted service. If You purchase a Hosted Service subscription, the foregoing limited warranty may not apply but You may be entitled to support services in connection with the Hosted Service as described further in your service description documents for the applicable Hosted Service. Contact Avaya or Avaya Channel Partner (as applicable) for more information.

#### Hosted Service

THE FOLLOWING APPLIES IF YOU PURCHASE A HOSTED SERVICE SUBSCRIPTION FROM AVAYA OR AN AVAYA CHANNEL PARTNER (AS APPLICABLE), THE TERMS OF USE FOR HOSTED SERVICES ARE AVAILABLE ON THE AVAYA WEBSITE, [HTTPS://SUPPORT.AVAYA.COM/LICENSEINFO](https://support.avaya.com/licenseinfo) UNDER THE LINK "Avaya Terms of Use for Hosted Services" OR SUCH SUCCESSOR SITE AS DESIGNATED BY AVAYA, AND ARE APPLICABLE TO ANYONE WHO ACCESSES OR USES THE HOSTED SERVICE. BY ACCESSING OR USING THE HOSTED SERVICE, OR AUTHORIZING OTHERS TO DO SO, YOU, ON BEHALF OF YOURSELF AND THE ENTITY FOR WHOM YOU ARE DOING SO (HEREINAFTER REFERRED TO INTERCHANGEABLY AS "YOU" AND "END USER"), AGREE TO THESE TERMS OF USE. IF YOU ARE ACCEPTING THE TERMS OF USE ON BEHALF A COMPANY OR OTHER LEGAL ENTITY, YOU REPRESENT THAT YOU HAVE THE AUTHORITY TO BIND SUCH ENTITY TO THESE TERMS OF USE. IF YOU DO NOT HAVE SUCH AUTHORITY, OR IF YOU DO NOT WISH TO ACCEPT THESE TERMS OF USE, YOU MUST NOT ACCESS OR USE THE HOSTED SERVICE OR AUTHORIZE ANYONE TO ACCESS OR USE THE HOSTED SERVICE. YOUR USE OF THE HOSTED SERVICE SHALL BE LIMITED BY THE NUMBER AND TYPE OF LICENSES PURCHASED UNDER YOUR CONTRACT FOR THE HOSTED SERVICE, PROVIDED, HOWEVER, THAT FOR CERTAIN HOSTED SERVICES IF APPLICABLE, YOU MAY HAVE THE OPPORTUNITY TO USE FLEX LICENSES, WHICH WILL BE INVOICED ACCORDING TO ACTUAL USAGE ABOVE THE CONTRACT LICENSE LEVEL. CONTACT AVAYA OR AVAYA'S CHANNEL PARTNER FOR MORE INFORMATION ABOUT THE LICENSES FOR THE APPLICABLE HOSTED SERVICE, THE AVAILABILITY OF ANY FLEX LICENSES (IF APPLICABLE), PRICING AND BILLING INFORMATION, AND OTHER IMPORTANT INFORMATION REGARDING THE HOSTED SERVICE.

#### Licenses

THE SOFTWARE LICENSE TERMS AVAILABLE ON THE AVAYA WEBSITE, [HTTPS://SUPPORT.AVAYA.COM/LICENSEINFO](https://support.avaya.com/licenseinfo), UNDER THE LINK "AVAYA SOFTWARE LICENSE TERMS (Avaya Products)" OR SUCH SUCCESSOR SITE AS DESIGNATED BY AVAYA, ARE APPLICABLE TO ANYONE WHO DOWNLOADS, USES AND/OR INSTALLS AVAYA SOFTWARE, PURCHASED FROM AVAYA INC., ANY AVAYA AFFILIATE, OR AN AVAYA CHANNEL PARTNER (AS APPLICABLE) UNDER A COMMERCIAL AGREEMENT WITH AVAYA OR AN AVAYA CHANNEL PARTNER. UNLESS OTHERWISE AGREED TO BY AVAYA IN WRITING, AVAYA DOES NOT EXTEND THIS LICENSE IF THE SOFTWARE WAS OBTAINED FROM ANYONE OTHER THAN AVAYA, AN AVAYA AFFILIATE OR AN AVAYA CHANNEL PARTNER; AVAYA RESERVES THE RIGHT TO TAKE LEGAL ACTION AGAINST YOU AND ANYONE ELSE USING OR SELLING THE SOFTWARE WITHOUT A LICENSE. BY INSTALLING, DOWNLOADING OR USING THE SOFTWARE, OR AUTHORIZING OTHERS TO DO SO, YOU, ON BEHALF OF YOURSELF AND THE ENTITY FOR WHOM YOU ARE INSTALLING, DOWNLOADING OR USING THE SOFTWARE (HEREINAFTER REFERRED TO INTERCHANGEABLY AS "YOU" AND "END USER"), AGREE TO THESE TERMS AND CONDITIONS AND CREATE A BINDING CONTRACT BETWEEN YOU AND AVAYA INC. OR THE APPLICABLE AVAYA AFFILIATE ("AVAYA").

Avaya grants You a license within the scope of the license types described below, with the exception of Heritage Nortel Software, for which the scope of the license is detailed below. Where the order documentation does not expressly identify a license type, the applicable license will be a Designated System License. The applicable number of licenses and units of capacity for which the license is granted will be one (1), unless a different number of licenses or units of capacity is specified in the documentation or other materials available to You. "Software" means computer programs in object code, provided by Avaya or an Avaya Channel Partner, whether as stand-alone products, pre-installed on hardware products, and any upgrades, updates, patches, bug fixes, or modified versions thereto. "Designated Processor" means a single stand-alone computing device. "Server" means a Designated Processor that hosts a software application to be accessed by multiple users. "Instance" means a single copy of the Software executing at a particular time: (i) on one physical machine; or (ii) on one deployed software virtual machine ("VM") or similar deployment.

#### License type(s)

**Designated System(s) License (DS).** End User may install and use each copy or an Instance of the Software only on a number of Designated Processors up to the number indicated in the order. Avaya may require the Designated Processor(s) to be identified in the order by type, serial number, feature key, Instance, location or other specific designation, or to be provided by End User to Avaya through electronic means established by Avaya specifically for this purpose.

#### Copyright

Except where expressly stated otherwise, no use should be made of materials on this site, the Documentation, Software, Hosted Service, or hardware provided by Avaya. All content on this site, the documentation, Hosted Service, and the product provided by Avaya including the selection, arrangement and design of the content is owned either by Avaya or its licensors and is protected by copyright and other intellectual property laws including the sui generis rights relating to the protection of databases. You may not modify, copy, reproduce, republish, upload, post, transmit or distribute in any way any content, in whole or in part, including any code and software unless expressly authorized by Avaya. Unauthorized reproduction, transmission, dissemination, storage, and or use without the express written consent of Avaya can be a criminal, as well as a civil offense under the applicable law.

#### Third party components

"Third Party Components" mean certain software programs or portions thereof included in the Software or Hosted Service may contain software (including open source software) distributed under third party agreements ("Third Party Components"), which contain terms regarding the rights to use certain portions of the Software ("Third Party Terms"). As required, information regarding distributed Linux OS source code (for those products that have distributed Linux OS source code) and identifying the copyright holders of the Third Party Components and the Third Party Terms that apply is available in the products, Documentation or on Avaya's website at:

<https://support.avaya.com/Copyright> or such successor site as designated by Avaya. The open source software license terms provided as Third Party Terms are consistent with the license rights granted in these Software License Terms, and may contain additional rights benefiting You, such as modification and distribution of the open source software. The Third Party Terms shall take precedence over these Software License Terms, solely with respect to the applicable Third Party Components, to the extent that these Software License Terms impose greater restrictions on You than the applicable Third Party Terms.

The following applies if the H.264 (AVC) codec is distributed with the product. THIS PRODUCT IS LICENSED UNDER THE AVC PATENT PORTFOLIO LICENSE FOR THE PERSONAL USE OF A CONSUMER OR OTHER USES

IN WHICH IT DOES NOT RECEIVE REMUNERATION TO (i) ENCODE VIDEO IN COMPLIANCE WITH THE AVC STANDARD ("AVC VIDEO") AND/OR (ii) DECODE AVC VIDEO THAT WAS ENCODED BY A CONSUMER ENGAGED IN A PERSONAL ACTIVITY AND/OR WAS OBTAINED FROM A VIDEO PROVIDER LICENSED TO PROVIDE AVC VIDEO. NO LICENSE IS GRANTED OR SHALL BE IMPLIED FOR ANY OTHER USE. ADDITIONAL INFORMATION MAY BE OBTAINED FROM MPEG LA, L.L.C. SEE [HTTP://WWW.MPEGLA.COM](http://www.mpegla.com).

#### **Service Provider**

THE FOLLOWING APPLIES TO AVAYA CHANNEL PARTNER'S HOSTING OF AVAYA PRODUCTS OR SERVICES. THE PRODUCT OR HOSTED SERVICE MAY USE THIRD PARTY COMPONENTS SUBJECT TO THIRD PARTY TERMS AND REQUIRE A SERVICE PROVIDER TO BE INDEPENDENTLY LICENSED DIRECTLY FROM THE THIRD PARTY SUPPLIER. AN AVAYA CHANNEL PARTNER'S HOSTING OF AVAYA PRODUCTS MUST BE AUTHORIZED IN WRITING BY AVAYA AND IF THOSE HOSTED PRODUCTS USE OR EMBED CERTAIN THIRD PARTY SOFTWARE, INCLUDING BUT NOT LIMITED TO MICROSOFT SOFTWARE OR CODECS, THE AVAYA CHANNEL PARTNER IS REQUIRED TO INDEPENDENTLY OBTAIN ANY APPLICABLE LICENSE AGREEMENTS, AT THE AVAYA CHANNEL PARTNER'S EXPENSE, DIRECTLY FROM THE APPLICABLE THIRD PARTY SUPPLIER.

WITH RESPECT TO CODECS, IF THE AVAYA CHANNEL PARTNER IS HOSTING ANY PRODUCTS THAT USE OR EMBED THE G.729 CODEC, H.264 CODEC, OR H.265 CODEC, THE AVAYA CHANNEL PARTNER ACKNOWLEDGES AND AGREES THE AVAYA CHANNEL PARTNER IS RESPONSIBLE FOR ANY AND ALL RELATED FEES AND/OR ROYALTIES. THE G.729 CODEC IS LICENSED BY SIPRO LAB TELECOM INC. SEE [WWW.SIPRO.COM/CONTACT.HTML](http://www.sipro.com/contact.html). THE H.264 (AVC) CODEC IS LICENSED UNDER THE AVC PATENT PORTFOLIO LICENSE FOR THE PERSONAL USE OF A CONSUMER OR OTHER USES IN WHICH IT DOES NOT RECEIVE REMUNERATION TO: (i) ENCODE VIDEO IN COMPLIANCE WITH THE AVC STANDARD ("AVC VIDEO") AND/OR (ii) DECODE AVC VIDEO THAT WAS ENCODED BY A CONSUMER ENGAGED IN A PERSONAL ACTIVITY AND/OR WAS OBTAINED FROM A VIDEO PROVIDER LICENSED TO PROVIDE AVC VIDEO. NO LICENSE IS GRANTED OR SHALL BE IMPLIED FOR ANY OTHER USE. ADDITIONAL INFORMATION FOR H.264 (AVC) AND H.265 (HEVC) CODECS MAY BE OBTAINED FROM MPEG LA, L.L.C. SEE [HTTP://WWW.MPEGLA.COM](http://www.mpegla.com).

#### **Compliance with Laws**

Customer acknowledges and agrees that it is responsible for complying with any applicable laws and regulations, including, but not limited to laws and regulations related to call recording, data privacy, intellectual property, trade secret, fraud, and music performance rights, in the country or territory where the Avaya product is used.

#### **Preventing Toll Fraud**

"Toll Fraud" is the unauthorized use of your telecommunications system by an unauthorized party (for example, a person who is not a corporate employee, agent, subcontractor, or is not working on your company's behalf). Be aware that there can be a risk of Toll Fraud associated with your system and that, if Toll Fraud occurs, it can result in substantial additional charges for your telecommunications services.

#### **Avaya Toll Fraud intervention**

If You suspect that You are being victimized by Toll Fraud and You need technical assistance or support, call Technical Service Center Toll Fraud Intervention Hotline at +1-800-643-2353 for the United States and Canada. For additional support telephone numbers, see the Avaya Support website: <https://support.avaya.com>, or such successor site as designated by Avaya.

#### **Security Vulnerabilities**

Information about Avaya's security support policies can be found in the Security Policies and Support section of <https://support.avaya.com/security>. Suspected Avaya product security vulnerabilities are handled per the Avaya Product Security Support Flow (<https://support.avaya.com/css/P8/documents/100161515>).

#### **Trademarks**

The trademarks, logos and service marks ("Marks") displayed in this site, the Documentation, Hosted Service(s), and product(s) provided by Avaya are the registered or unregistered Marks of Avaya, its affiliates, or other third parties. Users are not permitted to use such Marks without prior written consent from Avaya or such third party which may own the Mark. Nothing contained in this site, the Documentation, Hosted Service(s) and product(s) should be construed as granting, by implication, estoppel, or otherwise, any license or right in and to the Marks without the express written permission of Avaya or the applicable third party.

Avaya is a registered trademark of Avaya Inc.

All non-Avaya trademarks are the property of their respective owners.

Linux® is the registered trademark of Linus Torvalds in the U.S. and other countries.

#### **Downloading Documentation**

For the most current versions of Documentation, see the Avaya Support website: <https://support.avaya.com>, or such successor site as designated by Avaya.

#### **Contact Avaya Support**

See the Avaya Support website: <https://support.avaya.com> for product or Hosted Service notices and articles, or to report a problem with your Avaya product or Hosted Service. For a list of support telephone numbers and contact addresses, go to the Avaya Support website: <https://support.avaya.com> (or such successor site as designated by Avaya), scroll to the bottom of the page, and select Contact Avaya Support.



## Contents

<b>Important safety information</b>	<b>11</b>
<b>ATEX/IECEx Safety Instructions for 3749 Cordless Telephone.</b>	<b>12</b>
<b>Sensitive electronic environment (EU/EFTA only).</b>	<b>14</b>
<b>Regulatory compliance statements (EU/EFTA only)</b>	<b>14</b>
<b>Disposal of old equipment (EU/EFTA only)</b>	<b>15</b>
<b>Regulatory compliance statements (USA and Canada only)</b>	<b>16</b>
<b>Frequency range.</b>	<b>17</b>
<b>Power supply.</b>	<b>17</b>
<b>Safety precautions.</b>	<b>18</b>
<b>Usage.</b>	<b>19</b>
<b>Environmental requirements</b>	<b>20</b>
<b>Introduction</b>	<b>23</b>
<b>Functions and accessories</b>	<b>24</b>
<b>Descriptions</b>	<b>28</b>
<b>The Avaya 3740/3745/3749 DECT Telephone</b>	<b>30</b>
<b>Chargers</b>	<b>31</b>
<b>Desktop charger</b>	<b>31</b>
<b>Charging the telephone in desktop charger</b>	<b>32</b>
<b>Rackmount Charger</b>	<b>32</b>
<b>Multiple Battery Charger</b>	<b>32</b>
<b>Icons and text in the display</b>	<b>33</b>
<b>Keys and buttons</b>	<b>37</b>
<b>Hot keys</b>	<b>37</b>
<b>Multifunction/Alarm Button</b>	<b>37</b>
<b>Volume button</b>	<b>37</b>
<b>Sound off button</b>	<b>37</b>
<b>Alphanumeric keys</b>	<b>37</b>
<b>Accessories</b>	<b>38</b>
<b>Belt clips</b>	<b>38</b>
<b>Leather casing</b>	<b>39</b>
<b>Headset</b>	<b>39</b>
<b>Menu tree</b>	<b>40</b>
<b>Calls</b>	<b>40</b>
<b>Contacts</b>	<b>41</b>
<b>Profiles</b>	<b>42</b>
<b>Messaging</b>	<b>43</b>
<b>My favourites</b>	<b>44</b>
<b>Short cuts</b>	<b>44</b>
<b>Connections</b>	<b>45</b>
<b>Settings</b>	<b>46</b>

## Contents

In call . . . . .	47
Additional In Call Functions. . . . .	48
Customizing the menu tree . . . . .	48
Basic operation . . . . .	49
Turning the telephone On/Off . . . . .	49
Log In or Out of a Shared Phone . . . . .	49
Turning the audible signal On/Off . . . . .	51
Locking/Unlocking the keypad . . . . .	51
Locking/Unlocking the keypad in idle mode . . . . .	51
Locking/Unlocking the keypad during a call. . . . .	52
Locking/Unlocking the telephone. . . . .	52
Muting the ringtone for incoming call or message . . . . .	53
Calling . . . . .	54
Incoming call. . . . .	54
Answering a call . . . . .	54
Declining a call. . . . .	54
Ending a call . . . . .	55
Outgoing call. . . . .	55
Dialing a number (Pre-Dial) . . . . .	55
Dialing a number directly (Post-Dial) . . . . .	55
Dialing a number from the call list . . . . .	55
Dialing the sender of a message . . . . .	56
Dialing a number from the local phonebook. . . . .	56
Dialing a name from the company phonebook . . . . .	56
Dialing a name from the central phonebook. . . . .	57
During a call . . . . .	57
Adjusting the volume during a call . . . . .	57
Opening contacts during the call . . . . .	57
Opening messaging during the call . . . . .	58
Turning the microphone on/off during a call. . . . .	58
Transferring the audio. . . . .	58
Starting a new call during a call . . . . .	59
Toggling between calls . . . . .	59
Ending a call . . . . .	59
Call back . . . . .	59
Transferring a call . . . . .	60
Transferring to a new call . . . . .	60
Starting a conference Call. . . . .	60
Enabling call waiting. . . . .	60
Switch between Calls . . . . .	61

Answer Call Waiting . . . . .	61
Enabling DTMF . . . . .	62
DECT Info. . . . .	62
Using the loudspeaker. . . . .	62
Call diversion . . . . .	62
Declining a Call with a Predefined Message . . . . .	63
Emergency Calls . . . . .	63
Messaging . . . . .	64
Message list . . . . .	64
Sending a message . . . . .	64
Writing and sending a message . . . . .	64
Voice mail . . . . .	65
Receive a voice mail . . . . .	65
Checking the voice mail inbox . . . . .	65
Enabling one key voice mail access . . . . .	65
Menu operation . . . . .	66
Calls . . . . .	66
Call lists . . . . .	66
Missed Calls . . . . .	68
Call Time . . . . .	69
Push to talk Group Call . . . . .	69
Accepting an invitation . . . . .	69
Calling a PTT Group . . . . .	70
Re-joining a group . . . . .	71
Call Services . . . . .	71
Contacts . . . . .	73
Opening a personal phonebook . . . . .	73
Calling a contact . . . . .	73
Adding a contact. . . . .	74
Editing a contact. . . . .	75
Set Ring Signal for a Contact . . . . .	75
Delete Contact . . . . .	76
Central Phonebook . . . . .	76
Profiles . . . . .	77
Messaging . . . . .	78
Inbox . . . . .	79
Writing new messages . . . . .	82
Editing unsent messages . . . . .	83
Deleting a message or deleting all messages . . . . .	83
Sent messages. . . . .	83

## Contents

<b>Voice Mail</b> . . . . .	<b>85</b>
<b>Receive a Voice Mail.</b> . . . . .	<b>85</b>
<b>Check the Voice Mail inbox</b> . . . . .	<b>86</b>
<b>One Key Voice Mail Access</b> . . . . .	<b>86</b>
<b>My favourites.</b> . . . . .	<b>86</b>
<b>Adding favourites</b> . . . . .	<b>86</b>
<b>Editing favourites</b> . . . . .	<b>87</b>
<b>Deleting favourites.</b> . . . . .	<b>87</b>
<b>Short cuts</b> . . . . .	<b>87</b>
<b>Defining soft keys</b> . . . . .	<b>87</b>
<b>Defining hot keys</b> . . . . .	<b>88</b>
<b>Defining navigation key</b> . . . . .	<b>88</b>
<b>Defining multi-function button for 3740 telephones.</b> . . . . .	<b>89</b>
<b>Settings.</b> . . . . .	<b>90</b>
<b>Sound and Alert Settings</b> . . . . .	<b>90</b>
<b>Keypad Lock Settings</b> . . . . .	<b>92</b>
<b>Phone Lock Settings.</b> . . . . .	<b>93</b>
<b>Display Settings</b> . . . . .	<b>95</b>
<b>Time and Date Settings</b> . . . . .	<b>96</b>
<b>Answering</b> . . . . .	<b>97</b>
<b>Change Text size for Messages.</b> . . . . .	<b>98</b>
<b>Change the Menu Language</b> . . . . .	<b>98</b>
<b>Change Owner ID</b> . . . . .	<b>98</b>
<b>Alarm Settings</b> . . . . .	<b>98</b>
<b>Alarm Operations for 3749 telephones.</b> . . . . .	<b>100</b>
<b>Push-Button Alarm</b> . . . . .	<b>100</b>
<b>Test Alarm</b> . . . . .	<b>100</b>
<b>Personal Alarm.</b> . . . . .	<b>100</b>
<b>Man-Down and No-Movement Alarm</b> . . . . .	<b>101</b>
<b>Acoustic Location Signal</b> . . . . .	<b>101</b>
<b>Automatic Call after Alarm</b> . . . . .	<b>102</b>
<b>Connections</b> . . . . .	<b>102</b>
<b>Bluetooth</b> . . . . .	<b>102</b>
<b>Headset</b> . . . . .	<b>103</b>
<b>System</b> . . . . .	<b>104</b>
<b>In Charger Action when not in Call</b> . . . . .	<b>106</b>
<b>Procedure Call</b> . . . . .	<b>107</b>
<b>Advanced Functions.</b> . . . . .	<b>109</b>
<b>Admin menu</b> . . . . .	<b>109</b>
<b>Clearing lists in charger.</b> . . . . .	<b>109</b>



<b>Enhanced Messaging . . . . .</b>	<b>110</b>
<b>Receive a Message with Request for Answer . . . . .</b>	<b>110</b>
Accept/Reject the message . . . . .	110
<b>Message Queuing and Message Priority . . . . .</b>	<b>110</b>
<b>Message Priority and Call Priority . . . . .</b>	<b>111</b>
<b>Message Indication Repetition . . . . .</b>	<b>111</b>
<b>Color Messaging . . . . .</b>	<b>111</b>
<b>Interactive Messaging . . . . .</b>	<b>112</b>
<b>Message Templates . . . . .</b>	<b>113</b>
The Templates Menu. . . . .	114
<b>Answering a Text Message with a Predefined Message . . . . .</b>	<b>114</b>
<b>Mobile Data. . . . .</b>	<b>114</b>
Send Mobile Data . . . . .	114
Send Mobile Data with a Prefix . . . . .	115
<b>System handling . . . . .</b>	<b>115</b>
<b>Software Upgrade and Additional Features . . . . .</b>	<b>115</b>
<b>Handset Updates via Charging Rack . . . . .</b>	<b>115</b>
<b>Troubleshooting . . . . .</b>	<b>117</b>
<b>Operation Notice. . . . .</b>	<b>122</b>
<b>Accessibility and voice quality . . . . .</b>	<b>122</b>
Operating area . . . . .	122
Out of Range . . . . .	122
<b>Maintenance . . . . .</b>	<b>123</b>
<b>Maintenance of Batteries . . . . .</b>	<b>123</b>
Battery Warnings . . . . .	123
Charge the Battery. . . . .	123
Charge Spare Batteries . . . . .	123
Replace the Battery . . . . .	124
<b>Easy Replacement of Handset . . . . .</b>	<b>124</b>
Before Starting Easy Replacement Procedure. . . . .	125
Easy Replacement Procedure. . . . .	125
<b>Attach the Hinge-type Clip . . . . .</b>	<b>128</b>
<b>Attach the Swivel-type Clip . . . . .</b>	<b>128</b>
<b>Attach Cover for No Clip . . . . .</b>	<b>129</b>
. . . . .	130
<b>Bluetooth Headset for 3745 and 3749 phones . . . . .</b>	<b>131</b>
<b>Introduction to Bluetooth . . . . .</b>	<b>131</b>
<b>Wear . . . . .</b>	<b>131</b>
<b>Headsets . . . . .</b>	<b>132</b>
<b>Operation. . . . .</b>	<b>132</b>

## Contents

Enabling Bluetooth . . . . .	132
Pairing and connecting a Bluetooth headset . . . . .	133
Adding another Bluetooth headset . . . . .	133
Selecting a Bluetooth headset . . . . .	133
Removing a headset . . . . .	134
Changing the name of Bluetooth headset.. . . .	134
Calling . . . . .	134
Making a call . . . . .	134
Answering a call . . . . .	134
Ending a call . . . . .	135
Volume/Mute Control . . . . .	135
Adjusting the volume during a call . . . . .	135
Turning the microphone On/Off during a call . . . . .	135
Messaging . . . . .	135
Transferring a call . . . . .	135
Transferring a call to the telephone . . . . .	135
Transferring a call to the Bluetooth headset. . . . .	135
Toggling to a headset with cord . . . . .	136
Menu Tree . . . . .	136
Operation Notice. . . . .	136
Accessibility and Voice quality . . . . .	136
Operation area . . . . .	136
Out of range . . . . .	136
Environmental Requirements . . . . .	137
Bluetooth headset battery. . . . .	137
Troubleshooting . . . . .	137
Quick Reference Guide . . . . .	139
<b>Index . . . . .</b>	<b>150</b>

---

## Important safety information

Read this chapter before using the Avaya 3740/3745 DECT Telephones or Avaya 3749 DECT Telephone.

For safe and efficient operation of the telephone, observe the guidelines given in this manual and all necessary safety precautions when using the telephone. Follow the operating instructions and adhere to all warnings and safety precautions located on the product, the Quick Reference Guide and this User Manual.

This product shall only be used with the following batteries:

*Avaya 3740/3745 DECT Telephones:*

No. 700500841: DECT 3740/3745 HANDSET BATTERY PACK

*Avaya 3749 DECT Telephone:*

No. 700500842: DECT 3749 HANDSET BATTERY PACK

Chargers shall only be connected with power adapters included in the following charger kits:

*Basic Charger:*

No. 700479470: DECT 374x HANDSET BASIC CHARGER KIT EU

No. 700500871: DECT 374x HANDSET BASIC CHARGER KIT UK/NAR/AU

No. 700500872: DECT 374x HANDSET BASIC CHARGER KIT MEXICO

No. 700500873: DECT 374x HANDSET BASIC CHARGER KIT ARGENTINA

*Advanced Charger:*

No. 700479488: DECT 374x HANDSET ADV CHARGER KIT EU

No. 700500874: DECT 374x HANDSET ADV CHARGER KIT UK

No. 700500875: DECT 374x HANDSET ADV CHARGER KIT NAR

No. 700500876: DECT 374x HANDSET ADV CHARGER KIT AU

No. 700500877: DECT 374x HANDSET ADV CHARGER KIT BRASIL, MEXICO

No. 700500878: DECT 374x HANDSET ADV CHARGER KIT ARGENTINA

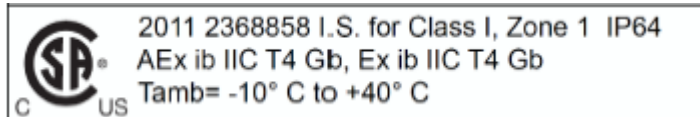
---

# ATEX/IECEX Safety Instructions for 3749 Cordless Telephone

## Intrinsically safe use



SIRA 10ATEX2072 IECEX SIR 10.0038  
II 2G, II 2D Ex ib IIC T4 Gb Ex ib IIIC T55 °C Db IP65  
Tamb= -10 °C to + 40 °C



## Charging the battery

When using in hazardous or classified areas, use an approved battery pack only. The battery pack must be marked with art. no 660274 on the label.

Charging parameters:  $U_m = 5.25V$ ,  $I_m = 1.15A$

For approved battery types, see certificate IECEx SIR 10.0038, or Sira 10ATEX2072 and following supplements.

The documents above and the EC Declaration of Conformity can be found at <http://www.avaya.com/gcm/emea/de/includedcontent/conformity.htm>.



### Important:

Battery charging or replacement is NOT permitted in a hazardous area. When charging the EX classified handset, it is only permitted to use a charger marked with DC3-CAAB/1A (or greater), DC4-CAAB/3A (or greater) or CR3-CAAB/2A (or greater) on the label. It is not permitted to charge the EX battery pack alone.

## Removing the battery

The battery pack is fastened by two screws that require a special tool, Battery pack opener for the ATEX/IECEX/CSA battery. The opener is delivered together with the handset and can also be ordered as a spare part.

To remove the battery pack, use the opener and untighten the screws. Remove the battery pack by pulling the screws. To fasten the battery pack use the opener and tighten the screws. See also [Replace the Battery](#) on page 124.



### Important:

Removing the battery pack is NOT permitted in a hazardous area.

## Attention

- The product is housed in an enclosure that meets IP65. However, the ATEX/IECEX classified telephone is not intended to be immersed in dust or water.
- In the case of suspected damage, do not use the ATEX/IECEX classified telephone in a hazardous area.
- Make sure that the product marking corresponds to the site requirements.
- Before installation consult the product documentation.
- National safety rules and regulations have to be observed.
- Do not use accessories to the product without ensuring that they are suitable for use in a hazardous area.
- Modification of the product is not permitted.
- Product repair has to be done at authorised repair shops only.

## Headset in ATEX/IECEx classified areas

In hazardous areas, it is only permitted to use the headset adapter for Peltor headset (art. no.: 660281) in combination with an ATEX/IECEx classified Peltor headset. The headset must be compatible with the output parameters of the headset connector as follows:

$U_o = 4.2 \text{ V}$   
 $I_o = 169 \text{ mA}$   
 $P_o = 583 \text{ mW}$   
 $C_o = 2.2 \text{ }\mu\text{F}$   
 $L_o = 2.2 \text{ }\mu\text{H}$

---

## Sensitive electronic environment (EU/EFTA only)

Only use this product in countries where the appropriate authorities have given their authorisation.

The CE symbol on the product certifies its conformity with the technical guidelines concerning user safety and electro-magnetic compatibility valid at the time of approval; in accordance with European directive No. 1999/05/EC.



The products Avaya 374x DECT Telephones comply with IP65 according to IEC 529 / EN 60 529.

Any radio-based equipment can potentially cause interference with other equipment and can be interfered from other equipment. This also applies for DECT equipment. However due to the very low transmission power level the changes for interference are very small. Research proves that operational DECT telephones normally don't influence electronic equipment however some precautions must be taken into account for sensitive electronic equipment e.g. sensitive laboratory equipment. When DECT telephones operate in straight nearness of sensitive electronic equipment incidental influence can appear. You are advised not to place the DECT telephone on or close (less then 10 cm) to this kind of equipment, even in standby mode.

---

## Regulatory compliance statements (EU/EFTA only)

### Permission and Conformity

We, Avaya Inc., declare that the product line DECT R4 concurs with the basic requirements and other relevant provisions of EU Directive 1999/5/EU concerning radio equipment and telecommunications terminal equipment and the mutual recognition of their conformity.

## Intended use

This equipment is intended for connection to radio interfaces (DECT) of Avaya PBX systems.

It is compliant with the essential requirements of the EU-Directive 1999/5/EU (Radio and Telecommunication Terminal Equipment, R&TTE).

Due to the differences of the individual public networks and network operators this compliance does not by itself give an unconditional assurance of successful operation at every network termination point. For the time being we are not aware of any network on which the equipment will not work due to its design.

In the event of problems, you should contact your equipment supplier or your Avaya service.

The conformity declaration can be accessed at the following Internet address:

<http://www.avaya.com/gcm/emea/de/includedcontent/conformity.htm>

or search the index using the key term "Conformity".

---

## Disposal of old equipment (EU/EFTA only)

Always dispose of old equipment correctly - keep our environment tidy.



Old electrical and electronic equipment marked with this symbol can contain substances hazardous to human beings and the environment. Never dispose of these items together with unsorted municipal waste (household waste). In order to protect the environment, public collection points have been set up to ensure the correct disposal of old electrical and electronic equipment marked with this symbol.

To reduce the risk of these substances being released into the environment and to reduce the burden on natural resources, it is also possible to participate in Avaya's used equipment return system. This system ensures the correct recycling of old equipment as well as the re-utilisation of individual components.

## Regulatory compliance statements (USA and Canada only)

Portables without Bluetooth	Portables with Bluetooth
FCC ID:BXZDH5	FCC ID:BXZDH5BL
IC: 3724B-DH5	IC: 3724B-DH5BL
US: 9FVW4NANDH5 HAC	US: 9FVW4NANDH5 HAC

### FCC compliance statements

This equipment has been tested and found to comply with the limits for a Class B digital device, pursuant to part 15 of the FCC Rules. These limits are designed to provide reasonable protection against harmful interference in a residential installation. This equipment generates, uses and can radiate radio frequency energy and, if not installed and used in accordance with the instructions, may cause harmful interference to radio communications. However, there is no guarantee that interference will not occur in a particular installation. If this equipment does cause harmful interference to radio or television reception, which can be determined by turning the equipment off and on, the user is encouraged to try to correct the interference by one or more of the following measures:

- Reorient or relocate the receiving antenna.
- Increase the separation between the equipment and receiver.
- Connect the equipment into an outlet on a circuit different from that to which the receiver is connected.
- Consult the dealer or an experienced radio/TV technician for help.

Privacy of communications may not be ensured when using this cordless telephone.

Use of non-manufacture approved accessories may violate the FCC RF exposure guidelines and should be avoided.

### Exposure to radio frequency signals

This equipment complies with FCC radiation exposure limits set forth for an uncontrolled environment. This device complies with FCC SAR limit of 1.6 W/kg. The maximum SAR value measured when used at the ear, and when worn on the body using belt clip:

SAR values	With Bluetooth	Without Bluetooth
Head	0.013 W/Kg	0.008 W/Kg
Body worn	0.016 W/Kg	0.011 W/Kg



This device and its antenna must not be co-located or operating in conjunction with any other antenna or transmitter.

### Information to user

This device complies with Part 15 of the FCC Rules. Operation is subject to the following two conditions:

- (1) this device may not cause harmful interference, and
- (2) this device must accept any interference received, including interference that may cause undesired operation.

### Modifications

Changes or modifications to the equipment not expressly approved by the party responsible for compliance could void the user's authority to operate the equipment.

### Hearing aid compatibility

This equipment is hearing aid compatible (HAC).

### IC requirements for canada

This Class B digital apparatus complies with Canadian ICES-003.  
Cet appareil numérique de la Classe B conforme à la norme NMB-003 du Canada.

---

## Frequency range

The telephone is a radio transmitter and receiver. When it is on, it receives and sends out radio frequency (RF) energy. The telephone operates on different frequency ranges depending on market and employs commonly used modulation techniques:

EU	1880-1900 MHz
USA	1920-1930 MHz
LA	1910-1930 MHz
BR	1910-1920 MHz

---

## Power supply

The mains voltage of the adapter should match the local mains voltage, this can be 110 V or 230 V. Check if both voltages do match before installing the charger and adapter.

---

## Safety precautions

- Do not open the cordless telephone or charger, this could expose you to high voltages. Have all repairs carried out by authorized service personnel.
- Avoid volume levels that may be harmful to your hearing. Exposure to excessive sound pressure from a telephone's earpiece or headset may cause permanent hearing loss.
- Do not allow the charger and the battery contacts to come into contact with conductive objects such as keys, paper clips, rings or bracelets.
- Do not allow the cordless telephone and charger to come into contact with water or chemicals.
- Only use the plug-in AC adapter and battery type supplied.
- Do not use AC adapters which are visibly damaged (cracked or broken housing) and keep the ventilation slits on the plug-in AC adapters free.
- Do not use the cordless telephones in vehicles or in hazardous locations.
- This product contains magnetic material. Be aware that small metallic objects may stick for example to the loudspeaker. This may deteriorate the audio quality and can be harmful.
- **Save this manual.** It includes important safety information and operating instructions. Save all instructions for future reference.
- Position the electrical cord to the AC power supply where it is least likely to be subjected to damage or stress.
- Remove the electrical cord from an outlet by pulling gently on the AC adapter, not by pulling the cord.
- Unplug the battery charger from a power source before cleaning the telephone to reduce risk of electric shock.
- Do not use auxiliary equipment with the telephone which is not exclusively recommended by the manufacturer, see [Accessories](#) on page 38. The use of any auxiliary equipment not recommended by the manufacturer may result in fire, electric shock, or injury, and will void the warranty.
- Do not expose the telephone to open flame.
- Do not expose the telephone and the charger to direct sunlight for long periods. Keep the telephone and charger away from excessive heat and moisture.
- Do not allow heavy objects to fall on the telephone.
- Do not allow children to play with the product packaging material. Product packaging material is often small and may present a choking hazard.
- Do not allow children to play with the telephone. It is not a toy. Children could hurt themselves or others. Children could also damage the telephone.
- Do not expose to prolong light.

---

## Usage

Like all other cordless telephones, this cordless telephone uses radio signals which do not guarantee a connection set-up under all circumstances. Generally, you should therefore not rely exclusively on cordless telephones when making indispensable calls (for example, medical emergencies).

---

## Environmental requirements

### Cordless telephone

- Use the DECT cordless telephones within the following temperature ranges:
  - For 3740 telephone, from -10 °C to +55 °C (14 °F to 131 °F)
  - For 3745/ 3749 telephone, from -10 °C to +40 °C (14 °F to 104 °F)
- Avoid exposing the telephone to direct sunlight or close to other heat sources.
- Do not expose the telephone to open flame.
- Keep the telephone away from excessive heat and moisture.
- Avoid sudden temperature changes to prevent condensation in the telephone. It is recommended to put the telephone into an air tight plastic bag until the temperature is adjusted, for example, when entering or leaving a cold/heated building on a warm/cold day.
- Protect your telephone from aggressive liquids and vapors.
- If the telephone has been exposed for water or condense, remove the battery immediately and let it dry completely before re-inserting the battery.
- Keep the telephone away from strong electromagnetic fields.
- Do not place a cold telephone in a charger.

### Battery

- Do not immerse the battery into water. This could short-circuit and damage the battery.
- Do not expose a battery to an open flame. This could cause the battery to explode.
- Do not allow the metal contacts on the battery to touch another metal object. This could short-circuit and damage the battery.
- Do not leave a battery where it could be subjected to extremely high temperatures, such as inside a car on a hot day.
- Use the Desktop Charger or the wall mounted Charging Rack for charging. Charge the battery for at least one hour the first time you use the battery. Note that the wall mounted charger with a battery pack adapter has to be used if the battery alone is to be charged.
- Do not charge a battery when the ambient room temperature is above 40 °C or below +5 °C (above 104 °F or below 41 °F).
- Do not attempt to take a battery apart.
- Do not disconnect the battery unless it needs to be replaced.
- Do power the telephone off before removing the battery.

### **Chemical resistance**

The alpha and numeric characters printed on the exterior of the telephone have been tested and found resistant to chipping, fading or wearing off when the telephone is treated with common cleaners and disinfectants or perspiration. The following chemicals have shown no harmful effect:

- 3% Hydrochloric Acid
- M-alcohol (85% Methylated Ethanol)
- 60% Chlorhexidin 0.5 mg/ml

Acetone can be damaging to the plastic casing of the telephone and should not be used.



---

## Introduction

This document describes features and settings available for the 3740/3745/3749 handsets. The 3740 handset is a feature-rich telephone with illuminated display, telephony and messaging. The 3745 handset is a feature-rich telephone with color display, telephony, messaging, and Bluetooth. The 3749 handset is feature-rich telephone with color display, telephony, messaging, and Bluetooth. The 3749 handset is a highly robust telephone for use in rough and demanding environments.

The handset is suitable for users dependent of being reachable and having a need for mobile voice and messaging features, which makes it ideal for applications where the user needs either one way messaging or to be able to interact with other users. The display enhances and simplifies the use of the handset.

There are three versions of the handset:

- 3740 Handset - with messaging functions,
- 3745 Handset - with messaging and alarm functions,
- 3749 Handset- EX classified handset with additional alarm functions for personal security.

Read the chapter “Descriptions” on page 28 before using the handset.

For software download and parameter set up, read the Installation and Operation Manual, Portable Device Manager (PDM), Windows Version and Configuration Manual, Avaya 374x Handsets.

### Quick reference guide

To get a quick overview on the basic functions of your telephone, see Quick Reference. Because of the handy format you can place a print-out next to your telephone as a quick reference.

## Functions and accessories

**Note:**

Some functions require settings in handset via PDM/Device Manager and/or system dependent.

**Table 1: Functions of 37xx telephones**

Functions	3740	3745	3749
Local phonebook	X	X	X
Company phonebook <sup>1</sup>	X	X	X
Procedure call	X	X	X
Phone restrictions	X	X	X
Central phonebook <sup>2</sup>	X	X	X
Call list with the 25 last calls	X	X	X
2 programmable soft keys	X	X	X
9 programmable hot keys	X	X	X
Programmable navigation key	X	X	X
Acoustic Location Signal (ALS)	-	X	X
Poll Location <sup>3</sup>	-	X	X
Man-down and No-movement alarm	-	-	X
Push button alarm	-	X	X



**Table 1: Functions of 37xx telephones**

Functions	3740	3745	3749
Multifunction button	X	-	-
Shared Phone	-	X	X
Push to Talk <sup>4</sup> (PTT)	-	X	X
Sending/receiving messages (SMS) <sup>2</sup>	X	X	X
Message acknowledgment	X	X	X
Interactive messaging	-	X	X
Colored messaging	-	X	X
Message templates	-	X	X
Voice mail access <sup>2</sup>	X	X	X
Enhanced DECT Security	X	X	X
Headset connector	X	X	X
Loudspeaking function	X	X	X
Microphone on/off during a call	X	X	X
Vibrator	X	X	X
Profiles	X	X	X
Easy replacement of handset	X	X	X

**Table 1: Functions of 37xx telephones**

Functions	3740	3745	3749
Easy replacement of battery	X	X	-
Clear lists in charger	X	X	X
Centralized Management <sup>2</sup>	X	X	X
Personalized menus	X	X	X
Dynamic Output Power	X	X	X
Site Survey tool	X	X	X
Bluetooth	-	X	X
Keypad backlight	X	X	-

1. This function/feature requires PDM or AIWS2.

2. This function/feature is system dependent.

3. Base Station Location must be enabled to use this feature.

4. This function/feature requires PDM/WSM3.

**Note:**

Use of the functions Central phonebook, SMS, Voice mail access, Call list, and Centralized Management are system dependent.

**Table 2: Accessories of 37xx telephones**

Accessories	3740	3745	3749
Basic Charger	X	X	X
Advanced Charger	X	X	X
Charging rack	X	X	X
Battery Pack Charger	X	X	-

**Table 2: Accessories of 37xx telephones**

<b>Accessories</b>	<b>3740</b>	<b>3745</b>	<b>3749</b>
Battery Pack Opener	-	-	X
Spare Battery	X	X	X
Leather Casing, incl. swivel-type clip	X	X	X
Spare Clip	X	X	X
Swivel-type Clip	X	X	X
Cover for no clip	X	X	X
Headset with Microphone on Boom <sup>1</sup>	X	X	X
Peltor Hearing Protection Headset	X	X	X
Headset adapter for Mic on Boom	X	X	X
EX-classified headset adapter for standard and EX-classified Peltor headset	X	X	X

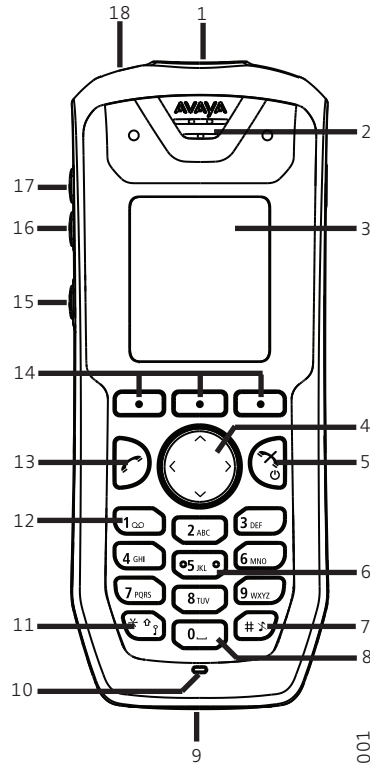
1. Requires the headset adapter for Mic on Boom.


---

# Descriptions

---

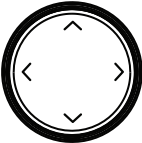







Figure 1: Description of the cordless telephone.






- 1  3740:  
Multifunction button  
The button is placed on the top side of the handset. Can be used as a shortcut to a certain function.  
3745/3749:  
Alarm button  
The button is placed on the top side of the handset and can be used for sending alarms or dial a predefined number.

**Note:** 3745 phones do not support man-down and no-movement.

- 2 Earpiece speaker

- 3 3745/3749:  
Colour display  
The full graphic type display is 128 pixels wide and 160 pixels high.  
The display has multiple colours and backlighting.  
3740:  
B/W display  
The full graphic type display is 128 pixels wide and 160 pixels high.  
The display is monochrome black and white, with backlighting.
- 4  Four-way navigation key  
Use this key to step in the menu and when working in text mode. <, >, ^, and v are used for stepping left/right and up/down in the menu. The navigation key can be programmed, the ^ is by default a shortcut to the Inbox, and v is a shortcut to Call contact. See also [Defining navigation key](#) on page 88. During a call the volume can be increased or decreased by pressing ^ and v.
- 5  On-hook and On/Off key  
Combined button; to end a call, to return to idle mode, and to switch the handset on/off by long press.
- 6  Tactile indicators  
There are two tactile indicators to indicate the centre of the key pad
- 7, 15  Sound off key/Mute/PTT button  
To turn on/off audible signals in idle mode, silencing the ring signal at incoming call and to mute in call.  
  
During a call, a long press on the button changes between microphone on/off.
- 8  Space  
To add space between text
- 9 Multi-purpose connector  
The connector is used for battery charging, software download, configuration and connection of an IP 65 classified headset connector.
- 10 Microphone  
The microphone is placed on the front bottom side of the handset.
- 11  Key lock and Upper/Lower case key  
This key is to lock the keypad in combination with the soft key "Lock". This key is also for switching between upper/lower case and digits.
- 12  Voice mail access<sup>1</sup>  
A quick access to the handset's Voice mail. See also [Voice mail](#) on page 65.
- 13  Off-hook key  
To answer a call, to pre-dial a number, and as a shortcut to the Call list.

- 14  Soft keys  
The three Soft keys are located just beneath the display and the function of each Soft key is indicated by text in the display just above the keys. In idle mode, the middle and right Soft key can be used for specific functions defined by the user of the handset. See [Defining soft keys](#) on page 87.
- 16  Volume button (down)  
To decrease the speaker earpiece, headset, and the loudspeaker volume. The button is placed on the upper left side of the handset.
- 17  Volume button (up)  
To increase the speaker earpiece, headset, and the loudspeaker volume. The button is placed on the upper left side of the handset.
- 18 LED  
Indicates incoming call, messaging, low battery, and charging.

1. This is a system dependent feature.

---

## The Avaya 3740/3745/3749 DECT Telephone



### Important:

The telephone may retain small magnetic objects around the microphone or the speaker region.

### Case

The plastic cover parts are made of durable PC/ABS material.

### Antenna

The antenna is integrated inside the cordless telephone.

### Loudspeaker

The cordless telephone has a separate loudspeaker for the loudspeaking function. The loudspeaker is placed on the back side of the cordless telephone.

### Microphone

The microphone is placed on the front bottom side of the cordless telephone.

### Clip

There are three different belt clip options to the cordless telephone; a hinge-type clip (standard), a swivel-type clip, or no clip. Using either of the three options, you can use the cordless telephone without any clip on. See [Attach the Hinge-type Clip](#) on page 128, or [Attach the Swivel-type Clip](#) on page 128. Use the clip to attach the telephone to a belt or similar.

## Battery

The battery is a rechargeable Li-Ion battery, placed under a battery cover. See [Replace the Battery](#) on page 124.

The battery is fully charged within four hours. See [Charge the Battery](#) on page 123.

The non-EX classified battery can be charged separately with a battery pack charger. See [Charge Spare Batteries](#) on page 123.

**IMPORTANT:** When charging the EX classified handset, it is only permitted to use a charger marked with DC3-CAAB/rev. 1A (or higher rev.), DC4-CAAB/rev. 3A (or higher rev.) or CR3-CAAC on the label. It is not permitted to charge the EX battery pack by itself.

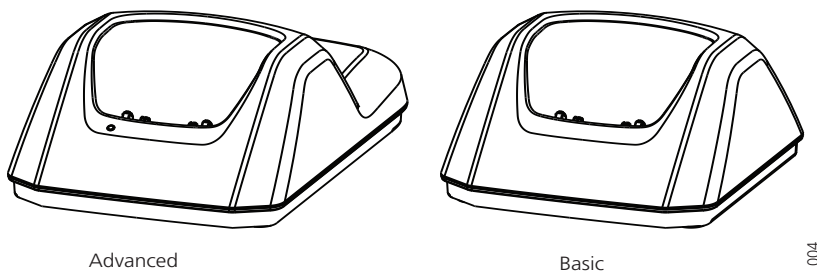
---

## Chargers

### Desktop charger

---

**Figure 2: Desktop chargers**



You can use one of the two desktop chargers available, one Basic charger that will only charge the cordless telephone, and one Advanced Charger with advanced functionality to download new software and synchronize parameters. The cordless telephone is fully operational while placed in the charger.

The Basic Charger is delivered with a plug-in power supply and is connected into an ordinary wall socket. The Advanced Charger is delivered with a power supply adapter. The adapter is connected with a power cord to the wall socket and the Charger itself is supplied from the adapter.



**Important:**

For 3749 telephones, battery charging or replacement is NOT permitted in a hazardous area.

For more information, see *Installation and Administration Manual, IP DECT*.

**Note:**

Only use the charger within the temperature range of +5 °C – +40 °C (+41 °F – +104 °F).



**Important:**

Only use the provided power supply, see *Installation and Administration Manual, IP DECT*.

## Charging the telephone in desktop charger

When the charger is connected to external power supply, normal operation is done as follows:

### Telephone charging

1. Place a cordless telephone in the charging slot to start charging.

### Telephone disconnection

1. Tilt the telephone forwards you.
2. Then, lift the telephone upwards.

**Note:**

Do not try to lift the telephone upwards before tilting it forwards.

## Rackmount Charger

The Rackmount Charger is used for charging several telephones, to synchronize parameters, and for software download.

The built in power supply can charge up to six cordless telephones.

See *Installation and Administration Manual, IP DECT*.

## Multiple Battery Charger

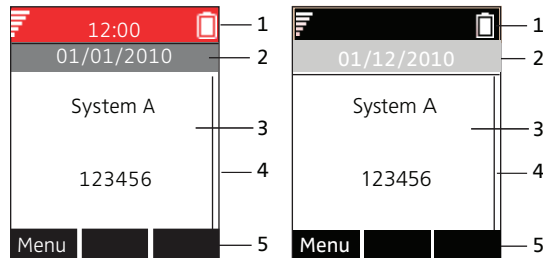
The Multiple Battery Charger is used for charging up to six spare batteries.



## Icons and text in the display

All functions and settings available to the user are shown as icons and text in the display. The icons and text in the display indicate functions and settings to which you have access. The display normally displays date and time, the Owner ID and telephone number. The Owner ID can manually be set by the user.

**Figure 3: Example of a display configuration in idle mode**



**Figure notes:**

- |                |                 |
|----------------|-----------------|
| 1. Status bar  | 4. Scroll bar   |
| 2. Header bar  | 5. Soft key bar |
| 3. Active area |                 |

The top row (**Status bar**) is used for icons which give you the information for signal strength, missed call, new message, phone lock, key lock, sound off, time and battery status. This row is always visible in all screens.

The next row (**Header bar**) displays the current date, headset connection, Bluetooth connection, and system connection.

The next rows (**Active area**) are used for information such as, profiles, the name of the system to which the cordless telephone is connected to. A user identity provided from the system and/or an Owner ID can also be displayed if configured in the Settings menu. This is also the area for pop up text for example, missed calls or to confirm an action.

The bottom row (**Soft key bar**) is used for Soft keys which can be used as short cuts for functions in the telephone. See [Hot keys](#) on page 37.

The (**Scroll bar**) is placed to the right side of the active area. It becomes visible when a menu screen has more than six menus, or if there are more than four rows of message text in a message.

**Note:**



For 3740 DECT telephones, the display is monochrome black and white, with backlight.















## Icons

3749	3745	3740	Display Icons
			"Signal strength" icon is visible in the upper left corner. The staples shown in display depends on the signal strength.
			"Full battery" icon is displayed in upper right corner.
			"Low battery warning" icon is shown when the battery has 10% or less remaining capacity left.
			"Empty battery warning" icon is flashing when the battery has 5% or less remaining capacity left.
			"Sound off" icon is displayed when the Sound off key or Mute button is pressed.
			"Microphone off" icon indicates a silenced microphone. It is displayed after a long press on the Sound off key, Mute button during a call.
			"Loudspeaking" icon is displayed in the soft key bar during a call. Pressing this icon turns on the loudspeaker.
			"Loudspeaking off" icon is displayed after the soft key for Loudspeaking icon has been pressed. Pressing this icon turns off the loudspeaker.
			"New message" icon or "interactive message" icon in the status bar indicates that one or more new text messages have been received. The icon remains in the status bar until all new messages in the inbox are read.
			"Voice mail message" icon is displayed in the status bar when there are voice mails. The icon remains until voice mail has been listened to.
			"Voice mail message" icon is displayed in the inbox when there are voice mails. The icon remains until voice mail has been listened.
			"Unread message" icon in front of a message indicates that this message is unread.
			"Request for answer" icon in front of a message indicates that this message must be acknowledged or rejected.
			"Read message" icon in front of a message indicates that this message has been read.
			"Unsent message" icon
			"Sent message" icon
			"New colored message" icon indicates that a new colored text message(s) has arrived. The messages can be labelled with different colors.

		"Read colored message" icon indicates that a colored text message(s) has been read. The messages can be labelled with different colors.	
		"High prio" icon included with "New message" icon indicates high priority of a message.	
		"Alarm prio" icon included with "New message" icon indicates alarm priority of a message.	
			"Key lock" icon indicates a locked keypad.
		"Locked entry" icon indicates that the contact can not be edited or deleted by the user.	
			"Phone lock" icon indicates a locked handset.
		"Bluetooth" icon indicates that Bluetooth is enabled. Only for 3745/3749.	
		"Bluetooth headset" icon indicates that a Bluetooth headset is connected to the handset.	
			"Headset" icon indicates that a corded headset is connected to the handset.
			"Outgoing call" icon is added to all outgoing calls in the call list.
			"Incoming call" icon is added to all answered calls in the call list.
			"Missed call" icon is added to all missed calls in the call list and in the status bar.
			"PDM/AIWS2 communication" icon is visible when handset is communicating with PDM/AIWS2 via advanced charger.
		"Man-down" icon indicates that the Man-down alarm is enabled only for the 3749 telephones.	
		"No-movement" icon indicates that the No-movement alarm is enabled only for the 3749 telephones.	

### Menu Icons

		The "Contacts" menu contains all names/numbers in the local phonebook. In addition, a company phonebook with up to 1000 entries can be downloaded to the phone via the PDM/AIWS2. A central phonebook <sup>1</sup> can also be accessed from the "Contact" menu.
---	---	--

		The "My favourites" menu can be used to create shortcuts the functions "Phone call" and "Send message".
		The "Messaging" menu contains all message handling such as reading and writing messages.
		The "Calls" menu contains call lists, call time, and call services*. Call services is configured in the PDM/AIWS2.
		The "Connections" menu contains Bluetooth connection (3745/3749 only), headset selection, System selection, and In charger selection.
		The "Settings" menu contains personal handset settings such as changing the ring volume, selecting language, etc.
		The "shortcuts" menu contains shortcuts for the Soft keys, Hot keys, and Navigation keys.
		The "Profiles" menu allows up to four different profiles to be added. The "Normal" profile is active by default.

1. This is a system dependent feature.

---

## Keys and buttons

### Hot keys

You can program a Hot key to give access to frequently used functions such as dialing a specific telephone number, a shortcut on the menu, or sending an SMS. Any key **0, 2 - 9** can be set to a Hot Key. A long press on any of these digits in stand by mode are by default a shortcut to the Call contact list.

### Multifunction/Alarm Button

The button is placed on the top side of the cordless telephone. On 3740, you can use this button as a shortcut to functions. The Multifunction/Alarm button supports long and double press modes. The Multifunction/Alarm button is by default not used, but you can define the use. On 3749, the Multifunction/Alarm button is used as an alarm button. The 3745 phones do not support man-down and no-movement functions.

### Volume button

The two buttons placed on the upper left side of the cordless telephone are used for increasing/decreasing the ear piece, headset, and the loudspeaker volume.

### Sound off button

The button is placed on the left side of the cordless telephone, next to the screen.

- While in a call a press on the button mutes the microphone.
- When the telephone is ringing a short press switches off the ringing tone temporarily.
- In idle mode a long press silences the telephone.

---

## Alphanumeric keys

**NOTE:** Depending on the selected menu language and character setting in the AIWS2, other characters can be available. This means that the character order can differ from the figure below.

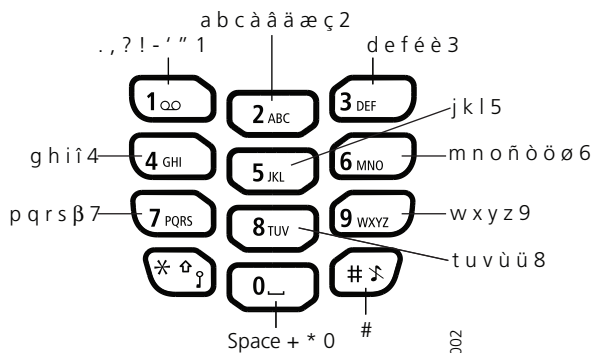


Figure 4. Available Characters.

### In Idle and Number Input Mode

- A short press on a key enter the digits “0” - “9” and the characters \* and #.
- Enter a pause in number input mode by a long press on **#**. A pause is indicated by a "P" in the display.
- A long press on **\*** changes the tone sender on. Tone sender on is indicated by a "T" in the display.

### In Text Input Mode

- A short press on a key 0-9, displays the first available character on that specific key. The marked character is selected after a timeout, or when another key is pressed.
- To change between upper and lower case, press **\*** before entering the character. The **\*** can also be used to display only the digits.
- To add space in the text, make a short press on key 0.
- The first character entered in a message, or when adding or editing a name in the Contacts menu, is an upper level character followed by lower level characters, unless **\*** is pressed before entering the character. To switch between "Abc", "ABC", "abc", and "123", press **\***. A long press on **#** displays special characters.

---

## Accessories

### Belt clips

You can use from the three belt clip options available:

- Hinge-type clip  
To prevent the telephone from slipping out of for example pocket or belt

- Swivel-type clip  
To be able to rotate without slipping out from the case
- No clip  
To be able to use the telephone without a clip  
To be able to use the telephone without a clip, a cover plate without a clip is also available.

## Leather casing

The leather casing is especially designed for the telephone. The casing comes with a swivel type belt clip and the telephone is fully operational while placed in the casing.

## Headset

Headsets are available with specific connectors if you frequently use the telephone and/or want to have both hands free.

You can order a headset adapter for Peltor headset with the telephone.



### **Important:**

In hazardous areas, you are permitted to use only the headset adapter for Peltor headset in combination with an ATEX/IECEX classified Peltor headset.

In order to achieve optimal audio quality with different headset types, you must select the corresponding headset profile.

The default setting is microphone on a boom, that is, the audio is optimized for using a headset with microphone on a boom. The headset profile can be changed in the **Connections** menu.

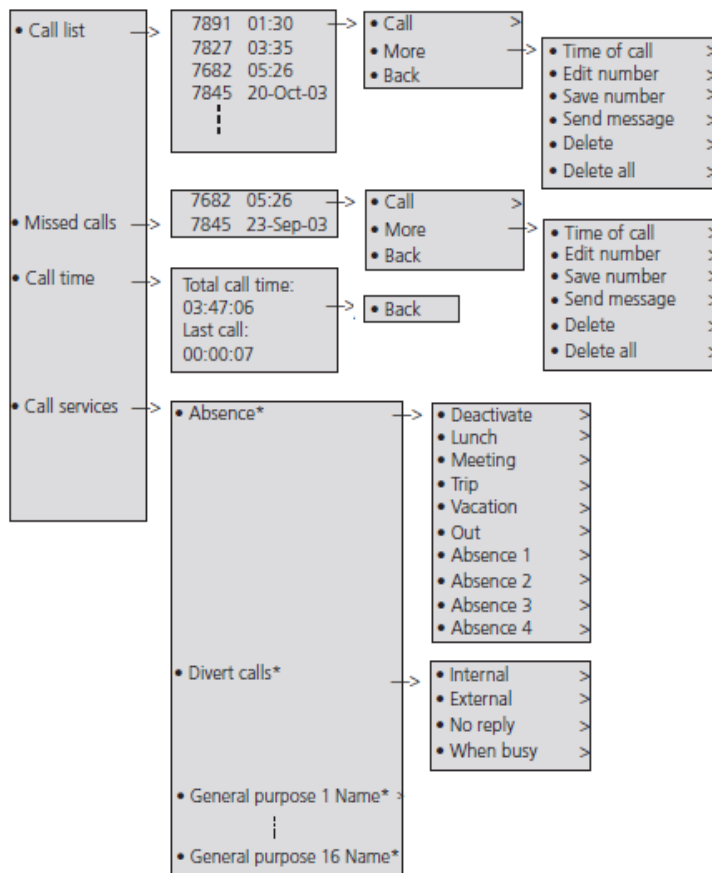
If the preconfigured headset profiles do not match the headset in use, or the audio performance needs to be optimized for a certain environment or user, you can configure your own headset profile. You can perform the configuration in the PDM. See *Installation and Administration Manual, IP DECT*. If a customized headset profile is configured in the PDM, you can select the profile in the telephone menu.

# Menu tree

**Note:**

In order to continuously improve the comprehensibility of menu terms, some of them in your telephone may differ from those used in the following menu trees.

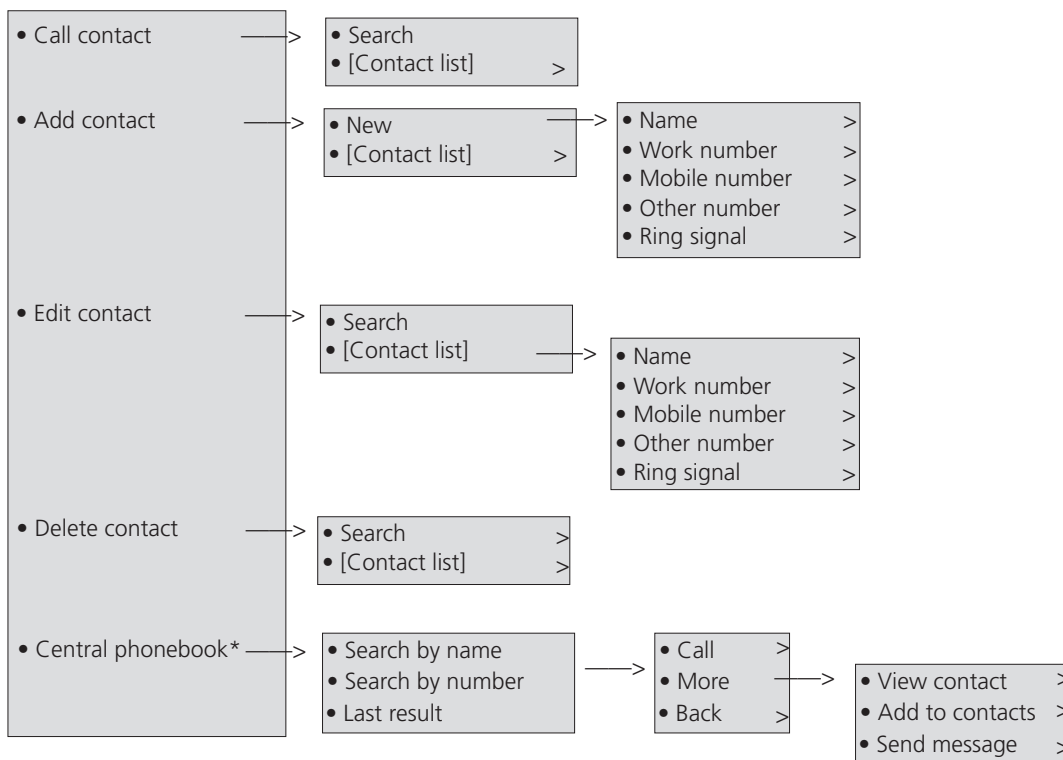
## Calls



\* Visible if defined in handset via PDM/Device Manager



# Contacts



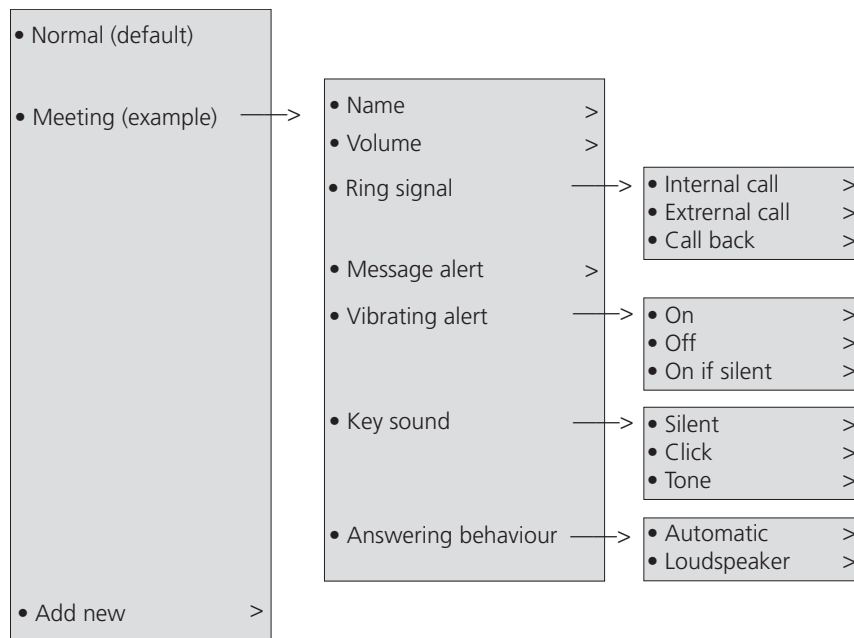
\* System dependent



**Tip:**

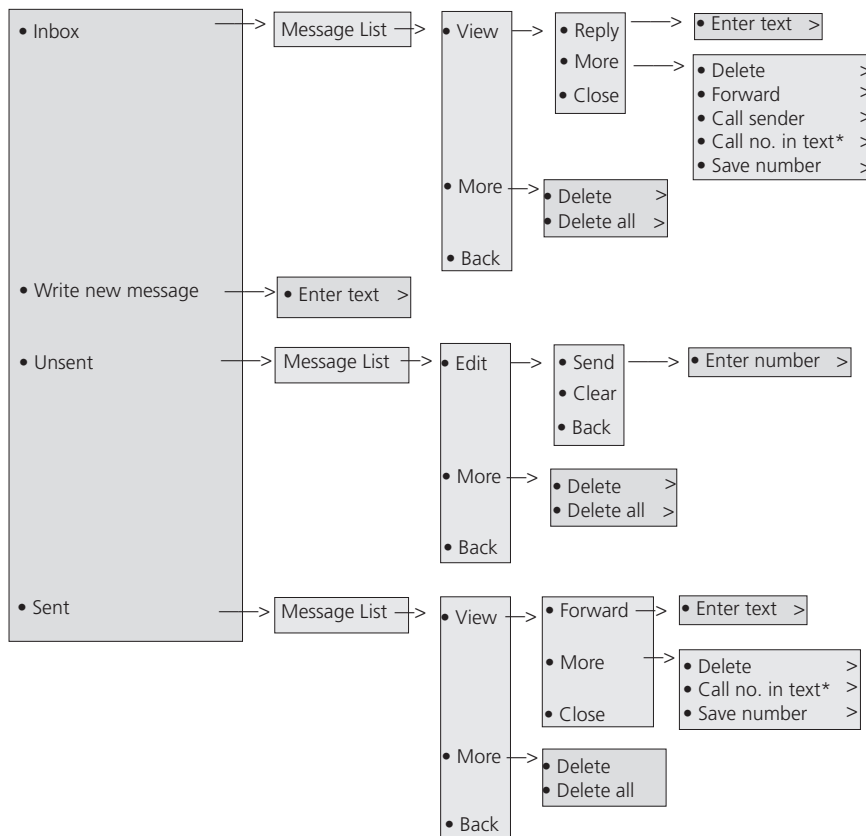
When adding or editing a number in a contact, a variable or character U can be added in the Work/Mobile/Other number field. This allows the user to enter additional numerical characters before calling the number. See [Admin menu](#) on page 109 for more information.

# Profiles



The example profile does not contain all applicable settings.

## Messaging



\*) Only visible if the number consists of minimum 3 digits.

\*) Call priority is used to set the importance of calls compared to messaging services. The setting determines whether:

- Call information presented on the display during incoming, ongoing and outgoing call, shall be suppressed when viewing a message.
- An ongoing call shall be disconnected when receiving a remote call setup request with answer mode property set to 'Automatic'.

Place the handset in the charger and configure call priority through Win PDM > Edit parameters > Settings > Messaging > Call priority.

- 0 = Overrides all messages and ongoing call is never disconnected.
- 1-9 = Comparison with message priority, highest priority will be shown and call setup priority higher or equal causes disconnection.

- 10 = Call indication on the display will always be suppressed and ongoing call will always be disconnected by call setup.

## My favourites

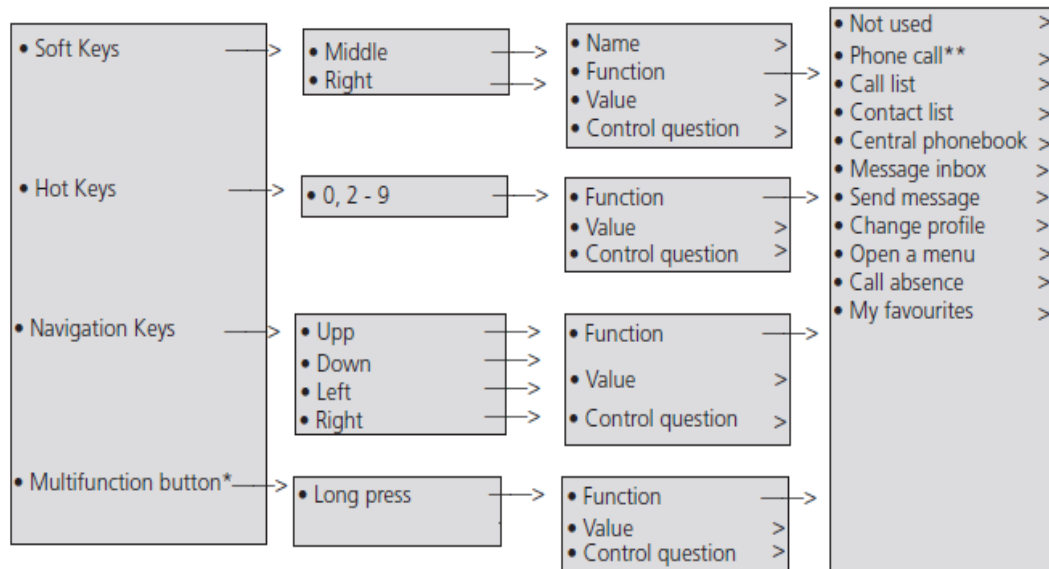


### Tip:

When configuring the Phone call function, a variable or character U can be added to the Enter number field. This allows the user to enter additional numerical characters before calling the number. See [Admin menu](#) on page 109 for more information.



## Short cuts



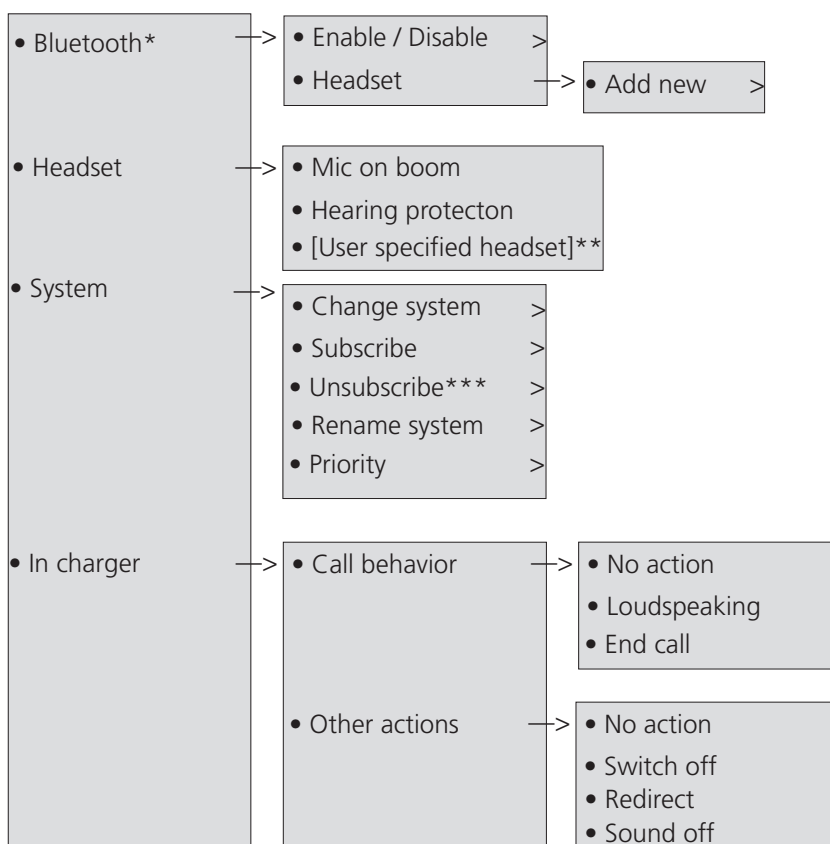
\*) Only applicable for 3740.

\*\*\*) Tip: When configuring the Phone Call function, a variable or character U can be added to the Enter number field. This allows the user to enter additional digits before calling the number. See [Admin](#)

[menu](#) on page 109 for more information.

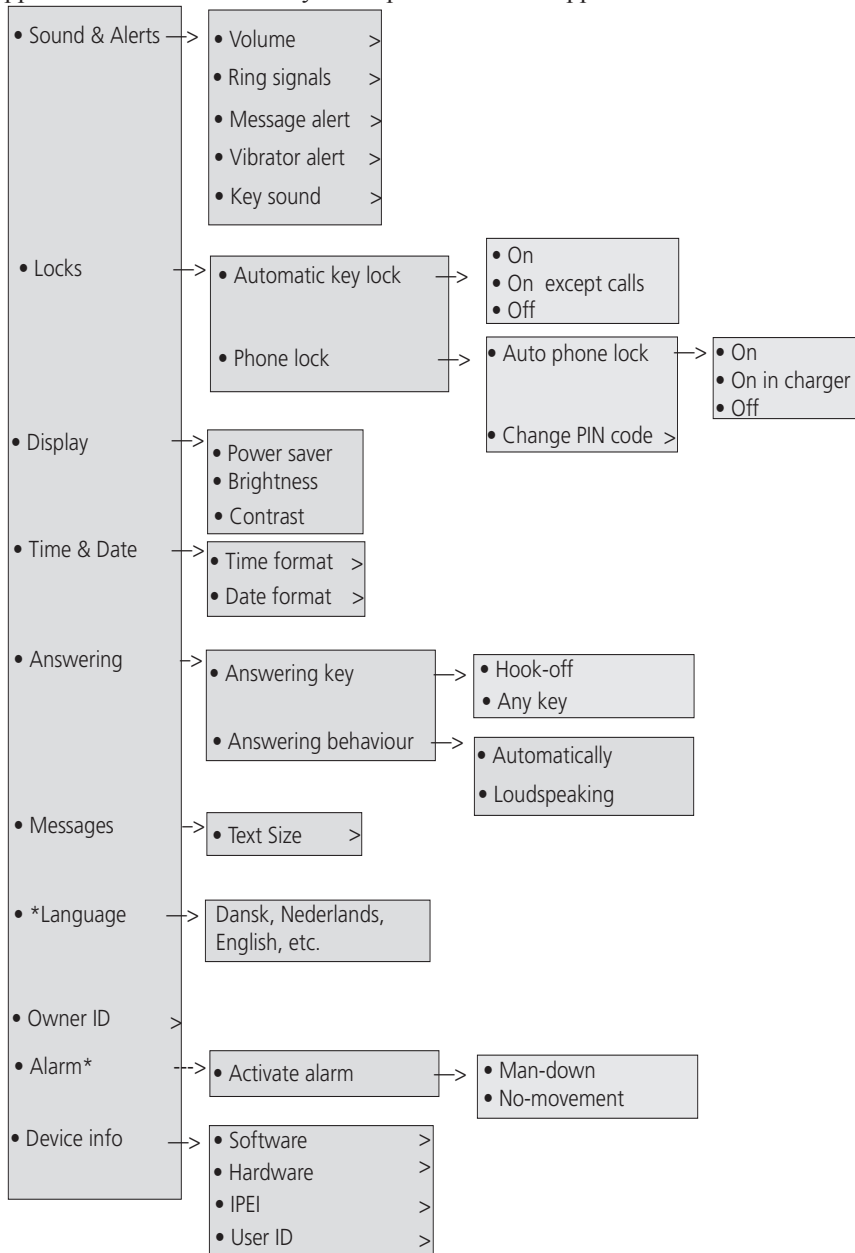
## Connections

\*) Only applicable for 3745/3749. \*\*) Visible if defined in PDM/AIWS2. \*\*\*) It is not possible to unsubscribe a protected system via the handset. Unsubscription must be performed via PDM/AIWS2.



# Settings

\*) Applicable for 3745/3749 only. 3745 phones do not support man-down and no-movement.



## In call

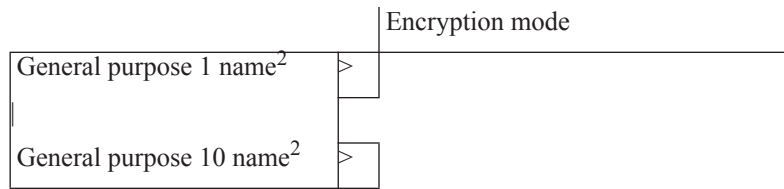
The In Call menu displays a list of functions that can be accessed during a call. To see the available functions, press the "More" soft key. Some functions are always provided and others may be made available by the administrator via the PDM/Device manager. To use a function, navigate the In Call menu to highlight the required function and then press the "Select" soft key.

The In call function can be used in combination with the Procedure call function. See chapter [Admin menu](#) on page 109.

**NOTE:** When calling from a locked handset, there are limitations to what items in the In Call menu are shown. However, the entire menu is accessible when calling from a handset with locked.

**NOTE:** If the handset is configured via PDM/Device Manager, one of the predefined emergency numbers can be called while the handset or keypad is locked. If calling from a locked handset, only the Microphone on/off function in the In Call menu can be accessed. However, the entire In call menu is accessible when calling from a handset with locked keypad.

Contacts	>	
Microphone on/off	>	
Audio transfer <sup>1</sup>	>	
New call <sup>2</sup>	>	Call "Phonebook access" Cancel
Switch <sup>2</sup>	>	
End call <sup>2</sup>	>	
Transfer <sup>2</sup>	>	
Transf. to new <sup>3</sup>	>	Call "Phonebook access" Cancel
Conference <sup>2</sup>	>	
Call back <sup>2</sup>	>	
Call waiting <sup>2</sup>	>	
DTMF		
DECT info <sup>4</sup>	>	Link System



1. Visible if a Bluetooth headset is connected (3745/3749 only)
2. Visible if defined in handset via PDM/AIWS2.
3. Visible if the parameters "New call" and "Transfer" are defined in handset via PDM/AIWS2.
4. Visible if the Admin menu is activated.

## Additional In Call Functions

Besides the default In Call functions, it is possible to define 10 extra system specific codes/general purposes. See the handset's Configuration Manual.

---

## Customizing the menu tree

The menu tree can be customized by hiding some of the functions that are available but for example not in use. Which functions that can be hidden are defined in the PDM/Device Manager. See the handset's Configuration Manual.



---

## Basic operation

---

### Turning the telephone On/Off

The telephone is switched off:

1. Press and hold **On-hook** key.  
The telephone will vibrate when it is on and the display lights up.

The telephone is in idle mode:

1. Press **On-hook** key long.  
A control question will be displayed.
2. Confirm with Soft key **Yes**.

**Note:**

The telephone returns to idle mode when pressing the **On-hook** key while in a menu.

**Note:**

If the administrator has enabled handset restriction for your handset, you might not be able to switch off the handset

---

### Log In or Out of a Shared Phone

**Note:** Shared Phone functionality is applicable in IP-DECT systems only. Shared Phone functionality is not applicable for 3740.

The feature shared phone allows more than one user to use a handset. When a handset is configured to be a shared phone, it can be used by any shared phone user in the system. The message and call lists are deleted when a user logs off a handset.

If the handset is configured in the PDM/Device Manager, an emergency call can be made from a handset that is logged off. See the handset's Configuration Manual.

#### Default Master ID

The parameter Default Master ID determines which IP-DECT Master the handset logs on to.

In a small IP-DECT system where a single IP-DECT Master is used, the parameter is not changed (default ID is "0").

In a large IP-DECT system where several IP-DECT Masters are used, the parameter may be changed depending on which IP-DECT Master to be used.

**Note:** If the handset is going to log on to another IP-DECT Master, the user can override the default Master ID by entering Master ID followed by the User ID in the following format:  
<\*><Master ID><\*><User ID>

## Enabling the shared phone using winPDM/ Device Manager

1. Select Systems > Common > Shared Phone.

**Note:** In the Default Master ID field, change the master ID if needed.

2. In the Phone mode drop-down list, select one of the following:
  - Personal - Select if the handset is intended to be used by one user only.
  - Shared - Select if the handset is intended to be shared between several users. Each user can log on the handset to obtain their personal extension number.
3. If a Personal extensions is converted into a Shared do the following:
  - Unsubscribe the handset.
  - Perform Step 2 and change to Shared.
  - Subscribe the handset.

## Log on a Handset

Prerequisite, the handset is switched on. See [Turning the telephone On/Off](#) on page 49 for more information.

1. A Login? dialog window appears. Press "Yes".
2. Enter User ID and password.
3. Press "Login".

**Note:** The user will be automatically logged out from a previously used handset.

When the handset is placed in a charger it is logged off, unless the user (through the phone) or admin (through winPDM) configures it to not log off automatically. Call list and message list are deleted when the handset is logged out. When it is removed from the charger, the user needs to log on again. An error message "Not Allowed" will appear if a user tries to login while another Handset is using the same extension, unless he performs a takeover. If a shared phone is used, it must be logged in to the system to be able to send an alarm.

## Log off a Handset

1. Press and hold .
2. A Logout? dialog window appears. Press "Yes".

**Note:** If a phone is shared and one of the users logs off the shared phone, the lock that prevents the handset from unauthorized use is deactivated. For additional information, see [Locking/Unlocking the telephone](#) on page 52.

---

## Turning the audible signal On/Off

**Note:**

If the parameter **Disable permanent mute** is enabled, you cannot turn off the audible signal. See *Installation and Administration Manual, IP DECT*.

Your telephone is in idle mode or rings.

1. Press the **Sound off** button long. The status of the telephone changes between ring signal on/off. To locate the button, see [Descriptions](#) on page 28.

The  icon indicates a silenced telephone.

---

## Locking/Unlocking the keypad

### Locking/Unlocking the keypad in idle mode

To prevent accidentally pressing keys and making a call, the keys can be locked.

#### Locking the keypad

1. Press the \* key.
2. Press the Soft key **Lock**.

#### Unlocking the keypad

1. Press the \* key.
2. Press the Soft key **Yes**.

**Note:**

You can answer/close an incoming call while the keypad is locked.

**Note:**

You can activate an automatic key lock. The keypad will be locked automatically a short time after the last keystroke. See [Activate the Automatic Key Lock](#) on page 92.

**Note:**

While placed in charger, a telephone's keypad is always unlocked.

**Note:**

A call can be answered or ended while the keypad is locked. If the handset is configured via the PDM/AIWS2. Predefined emergency numbers can also be called while the keypad is locked. Additionally, if the Multifunction button (3740 only) is configured as a shortcut to a predefined number, it can also be used while the keypad is locked. See handset's Configuration Manual.

## Locking/Unlocking the keypad during a call

To prevent accidentally pressing keys, the keys can be locked during a call. This can be useful when a headset is used and the handset is attached to a pocket or belt.

### Locking the keypad

1. Press the \* key for a few seconds.
2. Press the Soft key **Lock**.

### Unlocking the keypad

1. Press the \* key.
2. Press the Soft key **Yes**.



---

## Locking/Unlocking the telephone

The handset can be protected for unauthorized use. If this function is activated, a PIN code has to be entered, for example, to switch on the handset, to answer an incoming call etc. The default phone lock code (0000) can be changed to any 4 - 8 digit personalized code.

**NOTE:** If a phone is shared and one of the users logs off the shared phone, the lock that prevents the handset from unauthorized use is deactivated. For additional information, see [Log In or Out of a Shared Phone](#) on page 49.

**NOTE:** The handset can be configured with predefined emergency numbers that can be called while the handset is locked. Additionally, the Multifunction button<sup>1</sup> (3740) or Alarm button (3745/3749) can also be used while the handset is locked. See the handset's Configuration Manual.

1. Press "Menu".
2. Select  .
3. Select "Locks".
4. Select "Phone lock"
5. Select "Auto phone lock".

1. In this case, the Multifunction can only be used to call a predefined number configured via PDM/AIWS2.

6. Select "On", "On in charger", or "Off".
7. Enter PIN code. If the PIN code is forgotten it can be removed by the system administrator.
8. Press "OK".

### Unlocking the telephone

The phone shows the text "Turn off phone lock?"

1. Press Soft key **Yes**.
2. Enter PIN code
3. Press Soft key **OK**.

---

## Muting the ringtone for incoming call or message

You can mute the handset ringtone on an incoming call or message. The call is not hung up when the ringtone is muted. If the call is unanswered, it will revert to voicemail if the handset has been configured for voicemail. To mute an incoming call or message:

1. Long press the **Sound off** key while the phone is ringing.

---

# Calling

---



## Incoming call

The flashing LED, accompanied by a ring signal and/or a vibrating handset, gives a notice of a call. Ring signal and vibrator can be disabled, see [Sound and Alert Settings](#) on page 90.

The calling party's handset number or name is shown. The name is shown if the calling party's handset number is stored in the local phonebook.

**NOTE:** If the parameter *Stimuli call phonebook lookup* is disabled, the system-provided call information is used instead. This means that if a calling party's name is saved in the phonebook, it will not be displayed. This function is only applicable in legacy systems (stimuli).

## Answering a call

When the signal sounds, press  to answer the call, or press  to answer the call in loudspeaking mode<sup>1</sup>. The name or number of the calling party is displayed if calling line information is available.



**Tip:**

When a headset is connected to the handset, the headset button can be used to answer the call. |

A call may also be answered in the following ways:

- **Automatically and Loudspeaking:** When Automatically is enabled, all incoming calls are connected automatically. See [Settings](#) on page 46.
- **With a predefined message.** This lets the user decline the call, but still acknowledge its receipt, by sending a predefined text message to the caller. See [Answering a Text Message with a Predefined Message](#) on page 114.

## Declining a call

Your telephone rings.


1. Press **On-hook** key to decline the call.

**Note:**

A priority call cannot be declined.

1. When Bluetooth is enabled, the loudspeaker audio is lowered due to current limitations in the intrinsically safe handset.

## Ending a call

A press on  ends the call. The duration of the call is shown in the display. The total time of the call can also be retrieved from the Calls menu > Call time.


A call can also be ended by putting the handset in a charger. Note that all ongoing calls are disconnected. See [In Charger Action when not in Call](#) on page 106.


**Note:**

You can also to end a call by putting the handset in a charger. All ongoing calls will be disconnected if you use this method to end a call.

## Outgoing call

### Dialing a number (Pre-Dial)

Enter the number and press  to get the line. The number is shown on the display while dialing. If needed, press "Clear" to erase the number. By using the navigation key it is possible to step and add or delete a digit in a number.

The tone sender in a pre-dialed number can be turned on by long pressing .

An international number can be dialed from the handset by entering a + character followed by the country code and local number. To enter the + character, long press the 0 key until the character is shown in the display.

**NOTE:** The + character cannot be entered and international numbers cannot be dialed in the following circumstances:

- If the 0 key has been configured as a hot key.
- If the handset has been set up to perform advanced functions normally used by a system administrator, as described in [Admin menu](#) on page 109.

### Dialing a number directly (Post-Dial)



1. Press  to get the line and enter the number.




**Note:** The number is not added to the call list when pre-dial is used.

### Dialing a number from the call list





**Tip:**

A number can be dialed from the Call list by pressing , selecting a number from the list and pressing "Call" or .




1. Open the menu by pressing the "Menu" soft key.
2. Select  .
3. Select "Call list".
4. Select a number.
5. Press  or the soft key "Call" to dial. The number can be edited before the call is dialed. Press "More" and select "Edit number". The 25 last received, dialed or missed calls are stored in a call list. See [Calls](#) on page 40.

## Dialing the sender of a message





It is possible to call the sender of a message stored in the message list.

1. Open the menu by pressing the "Menu" soft key.
2. Select  .
3. Select "Inbox".
4. Select message in the message list.
5. Press "View".
6. Press "More".
7. Select "Call sender".

## Dialing a number from the local phonebook




1. Open the menu by pressing the "Menu" soft key.
2. Select  .
3. Select "Call contact".
4. Select contact from list, or search name/number by entering characters and select search.
5. Press "Call" or  to make the call.

## Dialing a name from the company phonebook

1. Open the menu by pressing the "Menu" soft key.
2. Select  .
3. Select "Call contact".
4. The local and company phonebook appears in the same list, but the company names are indicated by a icon  in front of the name. Select the contact from list, or search for the name or number by entering characters and selecting search.
5. Press the soft key "Call" or  to make the call.



## Dialing a name from the central phonebook

1. Open the menu by pressing the "Menu" soft key.
2. Select  .
3. Select "Central phonebook".
4. Select "Search by name".
5. Enter the first name, last name, or both.
6. Note: Incomplete names may be entered and searched. Names that include spaces may be also be searched.
7. Press "Search".
8. Press "Call", or  to make the call.

---



## During a call

**NOTE:** Some of these functions are system dependent. The parameters are set up in the PDM/Device Manager, see the handset's Configuration Manual, and Installation and Operational Manual for PDM/Device Manager.

If the handset is configured via PDM/Device Manager, one of the predefined emergency numbers can be called while the handset or keypad is locked. When calling from a locked handset, only the Microphone on/off function can be accessed by pressing the soft key "More". However, the entire In Call menu is accessible when calling from a handset with locked keypad.

## Adjusting the volume during a call


**Note:**

Press  to increase the volume, and  to decrease the volume. The handset stores and preserves the new volume level. The ^ and v on the navigation key can also be used to adjust the volume.

## Opening contacts during the call

1. Press "More" during the call.
2. Select "Contacts".
3. Select "Call contact" for searching a local or company phonebook contact, or select "Central phonebook" for searching a central phonebook contact.
4. Select or search contact.

**Note:**

The selected contact can be called by pressing "Call" or . When you access contacts during a call (normal call and PTT call), the first call is put on hold. When the user exits the contact menu, the call is activated automatically without pressing the Unhold button. See also [Starting a new call during a call](#) on page 59.

## Opening messaging during the call



The Messaging menu can be accessed during an ongoing call by pressing the soft key "More".

1. Press the soft key "More" during the call.
2. Select "Messaging".

See [Messaging](#) on page 43 for more information about messaging.



## Turning the microphone on/off during a call

1. Press "More" during the call.
2. Select "Microphone off".
3. Press "Select".

The icon   indicates a silenced microphone. This means that the other part in an ongoing call cannot hear you. To turn the microphone back on, do as follows:

4. Press "More" during the call
5. Select "Microphone on".
6. Press "Select".

The microphone can be turned on and off by long pressing  or .

When long pressing  or pressing , a short peep is also heard indicating that the microphone is turned on or off.

**Note:**

It also possible to turn the microphone off/on by a long press on the **Sound off** button, see [Descriptions](#) on page 28.

## Transferring the audio

To transfer audio between the Bluetooth headset and the telephone's earpiece during the call.


1. Press Soft key **More**.
2. Select **Audio transfer**.
3. Press Soft key **Select**.

**Note:**

**Audio transfer** is visible if Bluetooth connection is active.

## Starting a new call during a call

1. Press "More" during the call.
2. Select "New Call".
3. Press "Select".

**Note:** Enter the number and press , or "Call".

## Toggling between calls

You have started a new call during a call, and the first call is on hold.

1. Press Soft key **R**.

The telephone toggles between the calls.

**Note:**

You can also switch between the call via Soft key **More > Switch**.

## Ending a call

You have started a new call during a call, and the first call is on hold.

1. Press the **On-Hook** key.

This action ends the current call. The held call rings again as priority call.

**Note:**



You can also end the call via the Soft key **More > End Call**.

You can end a call by putting the telephone in a charger according to the **In Charger > Call behavior > End call** setting. Note that all ongoing calls will be disconnected. See *Installation and Administration Manual, DECT R4*.

## Call back

When a call is made to a busy handset, an automatically call back can be made when the busy handset is free. When a busy tone sounds, do as follows:

1. Press "More".
2. Select "Call back"
3. Press "Select".

4. Press  and wait until the handset alerts.
5. When the handset alerts, press  and the call automatically starts.

## Transferring a call

You have started a new call during a call, and the first call is on hold.

1. Press Soft key **More**.
2. Select **Transfer**.
3. Press Soft key **Select**.  
This action connects the first caller with the person you want to transfer the call to.

## Transferring to a new call

1. Press Soft key **More** during the call.
2. Select **Transfer to new call**.
3. Press Soft key **Select**.
4. Dial the number to the person you want to transfer the call to.
5. Press **Off-hook** key to transfer the call.

## Starting a conference Call

A new call is started during conversation, the first call is on hold.

1. Press Soft key **More**.
2. Select **Conference call**.
3. Press Soft key **Select**.

The person initiating the conference call is the conference leader, and the other are participant members of the conference call.

## Enabling call waiting

During a call, a second call appears and the a short tone is heard.

1. Press Soft key **More**.
2. Select **Call waiting**.
3. Press Soft key **Select**.  
Your are connected with the new caller. The other part is put on hold.

When the line is free it will automatically call the hold part again. This is system dependent.

**Note:**

You can also accept the second call by pressing the **Off-Hook** key.

## Switch between Calls

Prerequisite, a new call has been started during conversation, see [Starting a new call during a call](#) on page 59.

1. Press "More" during the call.
2. Select "Switch".
3. Press "Select" to switch to the other call. The first call is on hold.

If needed, repeat the steps above to switch between the calls.

## Answer Call Waiting

**NOTE:** Depending on system setup and configuration, this feature might be handled in one of two different ways:

### Method 1

During an ongoing conversation and a short tone for another incoming call appears, do as follows:

1. Press the soft key "More" during the call.
2. Select "Answer Call waiting".
3. Press "Select". The new call is now connected, and the first call is on hold.

When the line is free, the call on hold is automatically dialled again. This is a system dependent feature.

### Method 2

If a second caller calls during a phone call, the handset beeps and displays the text "Internal call" for internal callers and "External call" for external callers. The handset also shows the name or phone number of the second caller. To answer the second caller:

1. Press the soft key "Accept".
2. The text "Switch" briefly appears on screen, and the handset transfers to the second call. The first call is put on hold.
3. When finished speaking with the first caller, select the "More" soft key.
4. Select "End Call".
5. The second call is closed and the first call is retrieved.

**NOTE:** It is possible to reject a second call by pressing the "Decline" soft key. The second caller hears a busy tone, and the call is logged as a missed call in the handset.

## Enabling DTMF

Some systems or PBXs require that the handset sends Dual Tone Multi Frequency (DTMF) when pressing the keys. DTMF can be enabled as follows:

1. Press the soft key "More" during the call.
2. Select "DTMF".



**NOTE:** Press "Select" to enable the use of DTMF.

## DECT Info

This submenu is only visible if the Admin menu is activated. See handset's Configuration Manual.

## Using the loudspeaker

There are several options to activate the loudspeaking function:

- When receiving a call, press the soft key .
- During a call, press the soft key .
- During a call, put the handset in a charger. Requires that the parameter Call behaviour is set to "Put on Loudspeaker" in PDM/Device Manager. See the handset's Configuration Manual.
- This function can also be activated by selecting another answering method, that is, "Automatically" and/or "Loudspeaking". See [Answering a call](#) on page 54.

---

## Call diversion

Internal calls, external calls, calls when busy, or calls at no answer can be diverted to another telephone number.

The diversion is made via the Calls menu > Call services > Divert calls. See [Call Services](#) on page 71.

It is also possible to create a shortcut to the "Call Services" function or activate a call service when a profile is activated. See the handset's Configuration Manual for information.

**NOTE:** PBX settings for the call diversion must be set to show the Divert calls menu in the handset. See the handset's Configuration Manual.

It is also possible to create a shortcut to the "Call Services" function. See the handset's Configuration Manual for information.

---

## Declining a Call with a Predefined Message

A call may be declined with a predefined message by the called party provided that both parties are connected via an IP-DECT system. To decline a call with a predefined message when the handset rings, perform the following steps:

1. In response to the "Reply with a message template?" prompt, press the "Yes" soft key to send a message to the caller. A list of predefined messages is displayed in the "Templates" menu.
2. Select, and if required, edit the message as described in [The Templates Menu](#) on page 114.
3. Click the soft key "Send". The calling party number is displayed in the handset display.
4. Click the soft key "Send". A "Message sent" confirmation is displayed and the message is sent to the caller.

---

## Emergency Calls

If configured in the PDM/Device Manager, any one of up to five emergency numbers can be called. An emergency number can be called even if the handset or keypad has been locked. For additional information, see sections [Keypad Lock Settings](#) on page 92 and [Phone Lock Settings](#) on page 93.

---

## Messaging

For getting information on all Messaging functions see [Messaging](#) on page 43.

---

### Message list

The thirty last received messages are stored in a list. The message list is located in the Messaging menu **Inbox**. Time and date information is included in the message.

---

### Sending a message

- For text input keys 0-9, \* or # can be used.
- Key 0 and 1 contains special characters, see [Alphanumeric keys](#) on page 37 to see all characters.
- The maximum message length is 160 characters.

**Note:**

Some characters require 2 bytes in the final message, therefore you might not be able to enter 160 characters sometimes.

- For basic rules of text input, see [Alphanumeric keys](#) on page 37.

### Writing and sending a message

1. Enter **Messaging** menu.
2. Select **Write new message**.
3. Enter the message text.
4. Press Soft key **Send**.
5. Enter the call number
6. Press Soft key **Send** to send the message.



---

## Voice mail

### Receive a voice mail

A new voice mail is indicated by the icon **New message** in the status bar. Information is stored in the **Messaging** inbox, see [The example profile does not contain all applicable settings.](#) on page 42.

### Checking the voice mail inbox

1. Open the **Messaging** menu, see [The example profile does not contain all applicable settings.](#) on page 42.
2. Select **Inbox**.  
The voice mail will be displayed first in the inbox list.
3. Select the icon **Voice Mail**.
4. Press the Soft key **View**, and then **Call**.

Only one voice mail at the time will be displayed, even if there are more voice mail messages in the message list.

### Enabling one key voice mail access

To enable one key Voice Mail Access, you must download your mailbox extension number to the telephone, see *Installation and Administration Manual, IP DECT*.

Your telephone is in Idle mode.

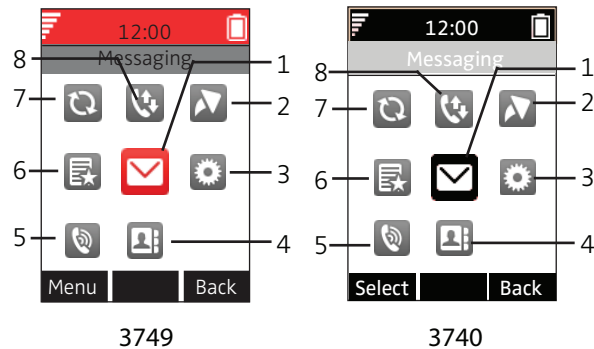
1. Perform a long press on digit key **1**.  
Your voice mail will be called. If the extension number is not available a pop-up **Voice mail number not defined** is displayed.
2. Follow the given instruction in the Voice Mail.

---

# Menu operation

---

Figure 5: The main menu.



**Figure notes:**

- |              |                  |
|--------------|------------------|
| 1. Messaging | 5. Profiles      |
| 2. Shortcuts | 6. My Favourites |
| 3. Settings  | 7. Connections   |
| 4. Contacts  | 8. Calls         |

**Note:**

For 3740 DECT telephones, the menu is in monochrome black and white.

---



## Calls


### Call lists

The 25 last received, dialled or missed calls are stored in a call list. If a number occurs more than once the last time stamp, together with the total number of occurrences, is shown.



1. Select **Call list**.
2. Step with the ▲ and ▼ to scroll in the list.

### Dialing a number from call list

1. Enter the menu by pressing the “Menu” soft key.
2. Select   in the menu.

3. Select "Call list".
4. Step with the  $\vee$  and  $\wedge$  to select number in the list.
5. Press "Call" or  to dial.

### Viewing the time of a call



1. Enter the menu by pressing the "Menu" soft key.
2. Select   in the menu.
3. Select "Call list".
4. Step with the  $\vee$  and  $\wedge$  to select number in the list.
5. Press "More".
6. Select "Time of call". The time and date is displayed.



#### Tip:



The duration of the last call is displayed under Call time, see [Call Time](#) on page 69.

### Editing a number from call list



1. Enter the menu by pressing the "Menu" soft key.
2. Select   in the menu.
3. Select "Call list".
4. Step with the  $\vee$  and  $\wedge$  to select number in the list.
5. Press "More".
6. Select "Edit number".

### Saving a number



**NOTE:** Saving a number in the call list creates a new contact. However, existing items in the call list are not updated with the contact information.

1. Enter the menu by pressing the "Menu" soft key.
2. Select   in the menu.
3. Select "Call list".
4. Step with the  $\vee$  and  $\wedge$  to select number in the list.
5. Press "More".
6. Select "Save number".



## **Sending a message**

1. Enter the menu by pressing the “Menu” soft key.
2. Select   in the menu.
3. Select "Call list".
4. Step with the ∨ and ∧ to select number in the list.
5. Press "More".
6. Select "Send message".


## **Deleting an entry from the call list**

1. Enter the menu by pressing the “Menu” soft key.
2. Select   in the menu.
3. Select "Call list".
4. Step with the ∨ and ∧ to select number in the list.
5. Press "More".
6. Select entry to delete.
7. Select "Delete".
8. Select "Yes" to delete the entry from the list.

## **Deleting all entries from the call list**




1. Enter the menu by pressing the “Menu” soft key.
2. Select   in the menu.
3. Select "Call list".
4. Step with the ∨ and ∧ to select number in the list.
5. Press "More".
6. Select "Delete all".

## **Missed Calls**

A missed call is by default indicated by a Missed call window and the icon . A time delay can also be set in the PDM/AIWS2 to determine when a call is to be considered as missed, see the handset Configuration Manual. These features require configuration in the handset via PDM/ Device Manager.

The user can view missed calls by pressing "Yes". If the user presses "No", the missed calls can be viewed as follows:

1. Enter the menu by pressing the “Menu” soft key.



2. Select   in the menu.
3. Select "Missed calls".
4. Step with the  $\vee$  and  $\wedge$  to select number in the list.
5. Press "Call", or  to call back.

As in Call List there is a soft key "More" which can be used to view the time/date of the call, edit the received number, add to contacts, and delete received numbers. See [Call lists](#) on page 66 for information about the functionality in soft key "More".

**NOTE:** If supported by the system, the number's contact name can be displayed in the list.


## Call Time

The total time of the previous call and last call is displayed.

1. Enter the menu by pressing the "Menu" soft key.
2. Select   in the menu.
3. Press "Select".
4. Select "Call time".

## Push to talk Group Call

**NOTE:** Push To Talk (PTT) functionality is not applicable for 3740.

The push-to-talk (PTT) function can be described as a group/conference call to a predefined group of members. If one of the group members wants to get in contact with the others, he/she simply presses and holds  to open the microphone.

To participate in the conference, the group members must first accept an invitation received as an incoming call. See [Accepting an invitation](#) on page 69.

If a member declines an invitation, he or she can re-join the group or conference later on. See [Re-joining a group](#) on page 71. A user can also invite a group of members to participate in a conference call by calling a PTT group, see [Calling a PTT Group](#) on page 70.




## Accepting an invitation

### Accept invitation received as an incoming call (PTT Basic):

A PTT invitation received as an incoming call is indicated by the incoming call icon. In the dialog window, a message containing maximum 24 characters can also be shown.



**Figure 6: Incoming invitation received as call**



1. Press "Accept", or .  
Default the handset starts in inverted mute and loudspeaking mode, but it can be configured differently in a PTT group.
2. Press and hold  to open the microphone for transmitting. The microphone is muted again when  is released.

**Invitation received as incoming call during an ongoing call:**

If a user receives an invitation during an ongoing call, it is displayed as an ordinary invitation, see [figure 6](#) on page 70. The user can either accept or decline the invitation by pressing "Accept" or "Decline", respectively.

**NOTE:** It is not possible to accept or decline the invitation by pressing  or , respectively.

If the user presses "Accept", the ongoing call is disconnected and the PTT call is connected.


Alternatively, the ongoing call can also be disconnected and the PTT call connected if the following is fulfilled:

- The handset is configured to answer invitations automatically
- The user does not respond to the invitation within 10 seconds

If the user declines the invitation, the he/she can re-join the PTT later on, see [Re-joining a group](#) on page 71.

## Calling a PTT Group

**NOTE:** PTT group(s) must be defined in the PDM/Device Manager and Messaging Group(s) in AIWS2 to be able to use this function. See the handset's Configuration Manual, and Installation and Operation Manual for AIWS2.

1. Press "Menu".
2. Select  in the menu.
3. Select "PTT groups".
4. Select PTT group.

5. Press "Call", or .

**Tip:**

Alternatively when in idle mode, press the PTT button quickly, select PTT group, and press the **Call** button.

## Re-joining a group

### Re-join a group from call list

If you receive a PTT invitation as a call and the you reject or miss it, you can dial the PTT group from the Call list or Missed calls, respectively. The PTT invitation is indicated by the icon in the list.



## Call Services

**Note:**

These functions are system dependent. The parameters are set up in the PDM or AIWS, see *Installation and Administration Manual, IP DECT*.



### Absence Handling

The reason for being absent and the return time can be specified here.

1. Enter the menu by pressing the "Menu" soft key.
2. Select   in the menu.
3. Select "Call services".
4. Select "Absence".
5. Select the applicable absence reason in the list. The number of absence reasons (for example "Lunch", "Meeting", "Trip" etc.) are configured in the PDM.
6. Press "Select".
7. Enter time (HHMM) or date (MMDD) depending on the selected absence reason.
8. Press "OK".

The handset sends an absence reason code to the system by establishing a call. The call is automatically disconnected after a few seconds.

### Deactivate the Absence Settings

1. Enter the menu by pressing the "Menu" soft key.
2. Select   in the menu.
3. Select "Call services".
4. Select "Absence".




5. Select "Deactivate".
6. Press "Select".

### **Diverting internal/external calls**

1. Select **Internal** or **External**.
2. Select **Activate**.
3. Enter number to divert to.
4. Press Soft key **OK**.

To stop diversion select **Deactivate** and press the confirmation button or the Soft key **OK**.




### **Diverting calls on No Reply**

1. Enter the menu by pressing the "Menu" soft key.
2. Select   in the menu.
3. Select "Call services".
4. Select "Divert calls"
5. Select "No reply".
6. Select "Activate".
7. Enter number (maximum 24 digits) to divert to, or press the soft key  to enter the call contact list.
8. Press "OK"

The handset sends a diversion reason code to the system by establishing a call. The call is automatically disconnected after a few seconds.

To stop diversion select "Deactivate" and press the soft key "OK".

### **Diverting calls when busy**

1. Enter the menu by pressing the "Menu" soft key.
2. Select   in the menu.
3. Select "Call services".
4. Select "Divert calls".
5. Select "When busy".
6. Select "Activate".
7. Enter number (maximum 24 digits) to divert to, or press the soft key  to enter the call contact list.
8. Press "OK".



The handset sends a diversion reason code to the system by establishing a call. The call is automatically disconnected after a few seconds.

To stop diversion select "Deactivate" and press the soft key "OK".

---

## Contacts

The telephone has a personal phonebook with 250 entries, where you can add, delete, and edit names and numbers freely. The phonebook lists all names in alphabetical order, where you can add three numbers for each contact; work number, mobile number, and other number.

You can also access a central phonebook. You can send a request to a messaging server with the first characters entered, and the messaging server returns a list of names and numbers that matches the search.

You can download a company phonebook through the PDM. Contacts from the Company phonebook appears in the contacts list menu with a lock symbol next to the name/number, which means that it is not editable. The contact will only include work number.




### Note:


You can import personal contacts or a local company phonebook by using WinPDM or DM. Refer the handset configuration manual in the *Installation and Administration Manual, IP DECT*.

## Opening a personal phonebook

1. Enter the menu by pressing the **Menu** Soft key, or the confirmation button on the Navigation key.
2. Select **Contacts** icon.
3. Press the confirmation button or the Soft key **Select**.

## Calling a contact




1. Enter the menu by pressing "Menu".
2. Select   in the menu.
3. Select "Call contact".
4. Select contact from the list, or enter name or number in the Search field.
5. Press "Call", or . the contact can also be edited and a message sent by selecting "View" > "More".

**Note:** It is not possible to edit a contact indicated by a icon  in front of the name.



## Adding a contact

**Note:** If the parameter *Stimuli call phonebook lookup* is disabled, the system-provided call information is used. This means that if a calling party's name is saved in the phonebook, it is not displayed. This function is applicable in legacy systems only (stimuli).

### Adding a new contact

1. Enter the menu by pressing "Menu".
2. Select   in the menu.
3. Select "Add contact".
4. Select "New".
5. Select "Add".
6. Enter a name, see [Alphanumeric keys](#) on page 37.
7. Press "OK".
8. Select "Work Number", "Mobile number", or "Other number".
9. Press "Add".
10. Enter number. A tone "T" or pause "P" can be included in phone numbers by pressing  5 times or 7 times, respectively.
11. TIP: A variable or character U can be added to the Work/Mobile/Other number field to allow the user to enter additional numerical characters before calling the number. See [Admin menu](#) on page 109 for more information.
12. Press "OK".
13. Press "Save".  
A specific ring signal can be set for each contact, see [Set Ring Signal for a Contact](#) on page 75.

### Adding from a call list


1. Enter the menu by pressing "Menu".
2. Select   in the menu.
3. Select "Add contact".
4. Select "From call list".
5. Select number in the list.
6. Press "Add".
7. Select "Work Number", "Mobile number", or "Other number".
8. Press "Add".
9. Enter name, see [Alphanumeric keys](#) on page 37.



10. Press "OK".
11. Press "Save".

A specific ring signal can be set for each contact, see [Set Ring Signal for a Contact](#) on page 75.

**Note:** If the parameter Force stimuli ringing is enabled, the handset uses the system-provided ring signals instead of the local ring signals. See the Configuration Manual for the Avaya 374x handsets. This function is applicable in legacy systems only (stimuli).

## Editing a contact

**Note:** It is not possible to edit a company phonebook contact. The contacts are indicated by a icon  in front of the name.

1. Enter the menu by pressing "Menu".
2. Select   in the menu.
3. Select "Edit contact".
4. Select contact.
5. Press "Edit".
6. Select "Name", "Work number", "Mobile number", "Other number", or "Ring signal".
7. Press "Edit".
8. Enter new name, number and/or select new ring signal.



### Tip:

A variable or character U can be added to the Work/Mobile/Other number field to allow the user to enter additional numerical characters before calling the number. See [Admin menu](#) on page 109 for more information.


9. Press "OK".
10. Press "Save".



## Set Ring Signal for a Contact

A specific ring signal can be set for each contact.

1. Add/edit a contact.
2. Select "Ring signal"
3. Select the ring signal to be used for the selected contact.
4. Press "Back" and the press "Save".

## Delete Contact

**NOTE:** It is not possible to delete a company phonebook contact. The contacts are indicated by a icon  in front of the name.



1. Enter the menu by pressing "Menu".
2. Select   in the menu.
3. Select "Delete contact".
4. Select contact.
5. Press "Delete".
6. Press "Yes" to confirm.

## Central Phonebook



In the central phonebook it is possible to search by name or number. The last search result can be displayed.

When the search result is displayed, it is possible to view contact information, add the number to new contact, and to send a message by pressing "More". It is also possible to call the number by pressing "Call".



### Search by Name

1. Enter the menu by pressing "Menu".
2. Select   in the menu.
3. Select "Central phonebook".
4. Select "Search by name".
5. Enter First name and/or Last name.
6. Press "Search". The search result is displayed.

### Search by Number

1. Enter the menu by pressing "Menu".
2. Select   in the menu.
3. Select "Central phonebook".
4. Select "Search by number".
5. Enter number.
6. Press "Search". The search result is displayed.

## View Last Search Result

1. Enter the menu by pressing "Menu".
2. Select   in the menu.
3. Select "Central phonebook".
4. Select "Last result". Only the last result is displayed.

---

## Profiles



It is possible to set up an own profile for incoming calls, message alerts, vibrating alerts, key sound etc. This can be useful when there are many users on the same telephone, and they want different sound profiles. It can also be used for temporarily settings, for example while in a meeting incoming calls should be silent. It is easy to switch between the different profiles.

### Note:

Changing settings is not possible on a telephone which is set to a profile. You have to leave the profile before.

1. Enter the menu by pressing the **Menu** Soft key, or the confirmation button on the Navigation key.
2. Select **Profiles** icon.
3. Press the confirmation button or the Soft key **Select**.

## Adding a new profile

1. Enter the menu by pressing "Menu".
2. Select   in the menu.
3. Select "Add new".
4. Enter name of the profile.
5. Press "Save".
6. Press "More" and then select "Add setting".
7. Select the setting you want to add to the profile.  
Repeat steps 6-7 if you want to add additional settings.
8. Mark the wanted setting and press "Edit" to make the changes.



**Note:** You can also use WinPDM to add a new profile.




### Tip:



A user can add a settings by importing a profile from an available profile. In Profile, press More > Import from > Select the available profile.

## Activating a profile



1. Enter the menu by pressing "Menu".
2. Select   in the menu.
3. Select profile from list.

When a profile is activated, the icon  and the name of the profile are displayed in idle mode.

## Deleting a profile


1. Enter the menu by pressing "Menu".
2. Select   in the menu.
3. Select profile from list.
4. Press "More".
5. Select "Delete" from menu.
6. Press "Select".
7. Press "Yes" to confirm.


## Editing a profile

1. Enter the menu by pressing "Menu".
2. Select   in the menu.
3. Select profile from list.
4. Press "More".
5. Select "Edit" from menu.
6. Select what to edit.
7. Make the changes.
8. Press "Save" to confirm.

---

## Messaging

**This applies to 3740:** When a text message is received, the LED starts flashing and the message alert signal sounds. The "New message" icon  and a "New Message" pop-up are displayed. The popup remains in the display until the user closes it. The icon remains in the display until all new messages are opened. If the message is received during a call, the user is notified with a beep.

**This applies to 3745 and 3749:** When a text message is received, the LED starts flashing and the message alert signal sounds. The “New message“ icon  and the content of the received message are automatically displayed. The icon remains in the display until all new messages are opened. If the message is received during a call, the user is notified with a beep.

Using the handset soft keys and menu selections, a received message can be replied to or forwarded to another party. The sender of the message can be called and a call number can be included in the message text.

A message can also be read later by pressing "Close". A received message is stored in the Inbox. See [Reading a stored message](#) on page 79.

**Tip:**

If you want to close several new messages quickly, press . The messages are indicated as unread messages in the Messaging inbox.

The thirty last received messages are stored in the inbox. Time and date information is included in the message.

**Tip:**



New messages and information about incoming calls can be displayed upside down. This can be useful if you wear the handset in a belt and want to read the message/call information without rotating the handset. When pressing any key, the messages are displayed in the normal way. See the handset's Configuration Manual for more information.

**NOTE:** If the phone is locked with a PIN, the user must unlock the phone to access a received message.



See also [Enhanced Messaging](#) on page 110 for additional messaging features.

## Inbox

### Reading a stored message



1. Enter the menu by pressing "Menu".
2. Select   in the menu.
3. Select "Inbox" to view the message list.
4. Select a message by using the  $\vee$  and  $\wedge$  on the navigation key.
5. Press "View".

### Replying to sender




1. Enter the menu by pressing "Menu".
2. Select   in the menu.

3. Select "Inbox" to view the message list.
4. Select a message by using the  $\downarrow$  and  $\uparrow$  on the navigation key.
5. Press "View".
6. Press "Reply".
7. Enter text. See [Alphanumeric keys](#) on page 37.
8. Press "Send".



### Deleting a message

1. Enter the menu by pressing "Menu".
2. Select   in the menu.
3. Select "Inbox" to view the message list.
4. Select a message by using the  $\downarrow$  and  $\uparrow$  on the navigation key.
5. Press "More".
6. Select "Delete".
7. Press "Yes" to delete the message.

### Forwarding a message

1. Enter the menu by pressing "Menu".
2. Select   in the menu.
3. Select "Inbox" to view the message list.
4. Select a message by using the  $\downarrow$  and  $\uparrow$  on the navigation key.
5. Press "View".
6. Press "More"
7. Select "Forward".
8. Enter additional text if needed. See [Alphanumeric keys](#) on page 37.
9. Press "Send".
10. Enter number, or press  $\star$   to access contacts in the local phonebook and the company phonebook.
11. Press "Send" to forward the message.

### Calling a sender

1. Enter the menu by pressing "Menu".
2. Select   in the menu.
3. Select "Inbox" to view the message list.







4. Select a message by using the  $\vee$  and  $\wedge$  on the navigation key.
5. Press "View".
6. Press "More".
7. Select "Call Sender".

### Calling a number in text



**NOTE:** Only possible if the number in the message text contains three or more digits.

**Note:** Only a single key is required to make a call to a number from a text message. If more than one number exists in the text message, you can select multiple numbers.

1. Enter the menu by pressing "Menu".
2. Select   in the menu.
3. Select "Inbox" to view the message list.
4. Select a message by using the  $\vee$  and  $\wedge$  on the navigation key.
5. Press "View".
6. Do one of the following:
  - Press "More" and select "Call no. in text".
  - Press .
7. If the message contains several numbers, select the number to be called from the list.
8. Press "Call", or .

### Saving a number

**Note:** If the user returns to the inbox immediately after having created a new contact, existing inbox items from that contact are not updated. The items are updated the next time the user opens the inbox.

1. Enter the menu by pressing "Menu".
2. Select   in the menu.
3. Select "Inbox" to view the message list.
4. Select a message by using the  $\vee$  and  $\wedge$  on the navigation key.
5. Press "View".
6. Press "More".
7. Select "Save number".
8. Select "Work Number", "Mobile number", or "Other number".

9. Press "Add".
10. Enter name. See [Alphanumeric keys](#) on page 37.
11. Press "OK".
12. Press "Save". The number is saved in the contact list.

## Writing new messages

A message can be constructed from scratch, or from a predefined template that can be used as it is or edited. For additional information about message templates, see [Message Templates](#) on page 113 . The maximum message length is normally 160 characters but may be less depending on the character set used.

The first character entered is always upper-case, followed by lower-case character. However, this may be overridden by pressing the \* -key before entering the character.


When pressing a key, the first available character for that key is displayed, See [Alphanumeric keys](#) on page 37. To enter the other characters supported by the key, press the key until that character appears in the display.

The keys 0-9, \* or # can be used. Keys 0 and 1 contains special characters, See [Alphanumeric keys](#) on page 37 to see all characters.

For example, to enter the character E, press key 3 twice. "E" appears in the display and is selected after a timeout or when another key is pressed.





### Tip:

If the system supports UTF-8 character encoding, the input language can be changed temporarily by long pressing  . This can be used to temporarily access characters in a foreign language.

To delete a character, press "Clear".


To construct and send a message, perform the following steps:

1. Enter the menu by pressing "Menu".
2. Select   in the menu.
3. Select "Write new message".
4. Write the message from scratch or select a message template by pressing the "More" soft key and, if required, edit the message as described in [The Templates Menu](#) on page 114.



**Note:** The "More" key is not displayed if no message templates have been defined.

5. Press "Send".



**Note:** A message can be saved and sent later by pressing the soft key "Back" and select "Yes". The message is stored under Unsent messages. See *Editing unsent messages*.

6. Enter number, or press  to access contacts in the local phonebook and the company phonebook.
7. Press "Send".



## Editing unsent messages

1. Enter the menu by pressing "Menu".
2. Select   in the menu.
3. Select "Unsent" to view the list.
4. Select message to edit/send.
5. Select "Edit", edit text and/or just select "Send".

## Deleting a message or deleting all messages

1. Enter the menu by pressing "Menu".
2. Select   in the menu.
3. Select "Unsent"
4. Select message in the list.
5. Select "More".
6. Select "Delete" or "Delete all".
7. Select "Yes" if the unsent messages are deleted.



## Sent messages


1. Enter the menu by pressing "Menu".
2. Select   in the menu.
3. Select "Sent" to view the list.
4. Select message in the list.
5. Press "View".

### Reading a sent message

1. Select **View** to read the message.

### Forwarding a message to another destination

1. Press "Menu".
2. Select   in the menu.

3. Select "Sent" to view the list.
4. Select message in the list.
5. Press "View".
6. Enter additional text if needed.
7. Enter number, or press  to access contacts in the local phonebook and the company phonebook.
8. Select "Send".

### **Review Inbox Content while Reading a Message**

To review the content of the inbox while reading a received message, perform the following steps:

1. Press the "More" soft key
2. From the pop-up menu, select "Inbox". The message summaries contained in the inbox are displayed.
3. To return to the message previously being read, press the "Back" soft key.

### **Calling while Reading a Text Message**

A user can make a call while reading a text message to review and discuss the message with the called party. The called party may be either:

- The message sender, that is, the same party that sent the text message
- A different party.

The user can activate the loudspeaker function during the call to make it easier to read the received text message while talking to the called party.

### **Calling the Message Sender**

To call the message sender while reading and reviewing a received text message, perform the following steps:

1. Receive the text message and call the message sender as described in [Calling the Message Sender](#) on page 84.
2. Wait for the called party to reply. The message is replaced by the ongoing call details. The user may now:
  - Continue with the call without referring back to the received message.
  - Redisplay the message and continue the call to further review and discuss the message. See [Redisplay the Message and Continue with the Call](#) on page 85.
  - Redisplay the message and terminate the call. See [Redisplay the Message and Terminate the Call](#) on page 85.

## Calling a Different Party

To call another party to read and review a received text message, perform the following steps:

1. Open the message as described in [Messaging](#) on page 43 and press the "More" soft key.
2. From the pop-up menu, navigate to the "Call" menu item and press the "Select" soft key. The pre-dial screen is displayed. Enter the number of the party to be called or select a number from the handset call list or local or central phone books.
3. Press the "Call" soft key and wait for the called party to reply. The message is replaced by the ongoing call detail. The user may now:
  - Continue with the call without referring back to the received message.
  - Redisplay the message and continue the call to further review and discuss the message. See [Redisplay the Message and Continue with the Call](#) on page 85.
  - Redisplay the message and terminate the call. See [Redisplay the Message and Terminate the Call](#) on page 85

### Redisplay the Message and Continue with the Call

1. To redisplay the message while the call is ongoing, select the "More" soft key.
2. From the pop-up menu, select "Messaging".
3. From the Messaging menu, select "Inbox". The received message summary is displayed.
4. Press the "View" soft key to display the message in full. If required, use the four-way navigation key to scroll up and down a long text message to reveal the content while reviewing and discussing the message with the called party.

### Redisplay the Message and Terminate the Call



1. Press . The call is terminated and the ongoing call summary details are replaced by the redisplayed text message.


---

## Voice Mail

**NOTE:** This feature is only available if configured in the system.





### Receive a Voice Mail

When receiving a voice mail, the content of the voice mail notification is displayed automatically on the screen, and is also indicated by the icon   in the status bar.


If the content of the notification is displayed, press "Call" to dial the voice mail. If "Close" is selected, it is possible to dial the voice mail by a long press  in idle mode, or from the Inbox menu.

Information is stored in the "Messaging" inbox until all voice mail messages have been listened to. See [Checking the voice mail inbox](#) on page 65.

## Check the Voice Mail inbox

1. Enter the menu by pressing "Menu".
2. Select   in the menu.
3. Select "Inbox". The voice mail is displayed first in the inbox list.
4. Select the message with the icon  in front of the message (a voice mail is always displayed first in the inbox list). Only one voice mail at the time is displayed even if there are more voice mail messages in the message list.
5. Press "View".
6. Press "Call", or .

## One Key Voice Mail Access

A long press on  in idle mode will call the voice mail. If the extension number is not available, a dialog window "Voice mail number not defined" is displayed. Some systems require that the mailbox extension number is downloaded to the handset, see the handset's Configuration Manual.

---

## My favourites



With this menu it is possible to customize your own menu with services/functions that are used often. A list of predefined services/functions are available for example; Write new message, Central phonebook, Call contact, etc.



### Tip:



If configuring the Phone call function, it is possible to add a variable/character U in the Enter number field that allows the user to enter additional numerical characters before calling the number. See [Admin menu](#) on page 109 for more information.

## Adding favourites



1. Enter the menu by pressing "Menu".
2. Select   in the menu.
3. Select "Add new".
4. Enter a name of the service in the field, and then press "OK"

5. Select a function using  $\downarrow$  and  $\uparrow$  on the navigation key.
6. If needed, enter values in the fields (only applicable for some of the functions)
7. Press "Back".

## Editing favourites

1. Enter the menu by pressing "Menu".
2. Select   in the menu.
3. Mark a service using the  $\downarrow$  and  $\uparrow$  on the navigation key.
4. Press "More"
5. Select "Edit".
6. Edit the service parameters and press "Back"

## Deleting favourites

1. Enter the menu by pressing "Menu".
2. Select   in the menu.
3. Mark a service using the  $\downarrow$  and  $\uparrow$  on the navigation key.
4. Press "More".
5. Select "Delete" using the  $\downarrow$  and  $\uparrow$  on the navigation key, and press "Select"
6. Press "Yes" to delete the service.
7. Press "Back".

---

## Short cuts



Predefined functions can be set as shortcuts for the Soft Keys, Hot keys, Navigation keys, and Multifunction button. It is for example possible to define the Soft Key to make a call or as a shortcut to send a message.

**NOTE:** The Multifunction button is not applicable for 3745/3749



**TIP:** When creating a shortcut to the Phone call function, it is possible to add a variable/character U in the Enter number field that allows the user to enter additional numerical characters before calling the number. See [Admin menu](#) on page 109 for more information.

## Defining soft keys



1. Enter the menu by pressing "Menu".

2. Select   in the menu.
3. Select "Soft Keys".
4. Select "Middle" or "Right".
5. Enter a name for the Soft Key. See [Alphanumeric keys](#) on page 37.
6. Press "OK".
7. Select "Function".
8. Select function from list, and press "Back".
9. Select "Value" (only for some of the functions), and press "Select". Enter a value, for example a number. Press "Back".
10. Select "Control question", and press "Select". It is off by default. Press "Back".  
If the control question is enabled, a Proceed? dialog window is displayed when pressing the defined Soft key. Press "Yes" to proceed.
11. Press "Save".

## Defining hot keys

1. Enter the menu by pressing "Menu".
2. Select   in the menu.
3. Select "Hot keys".
4. Select "0", "2" to "9".
5. Select "Function".
6. Select function from list, and press "Back".
7. Select "Value" (only for some of the functions), and press "Select". Enter a value for example a number. Press "Back".
8. Select "Control question", and press "Select". It is off by default.  
If the control question is enabled, a Proceed? dialog window is displayed when pressing the defined Hot key. Press "Yes" to proceed.
9. Press "Save"

## Defining navigation key

1. Enter the menu by pressing "Menu".
2. Select   in the menu.
3. Select "Navigation keys".
4. Select "Up", "Down", "Left", or "Right".
5. Select "Function".




6. Press "Select" to select function for the key.
7. Select function from list, and press "Back".
8. Select "Value" (only for some of the functions). Enter a value for example a number. Press "Back".
9. Select "Control question".  
It is disabled by default. If the control question is enabled, a Proceed? dialog window is displayed when pressing the defined key. Press "Yes" to proceed.
10. Press "Save".

## Defining multi-function button for 3740 telephones

The Multifunction is not applicable for 3745/3749.

The Multifunction button can be defined with two different functions; a long press activates one function, and a double press activates another function.

1. Enter the menu by pressing "Menu".
2. Select  in the menu.
3. Select "Multifunction button".
4. Select "Long press" or "Multi press".
5. Select "Function".
6. Select function from list, and press "Back".
7. Select "Value" (only for some of the functions). Enter a value for example a number. Press "Back".
8. Select "Control question".  
It is disabled by default. If the control question is enabled, a Proceed? dialog window is displayed when pressing the defined key. Press "Yes" to proceed.

**Note:** If the Multifunction button is configured as a shortcut to a Phone call function, it is still possible to use the button while the handset/keypad is locked. The condition is that the control question is disabled.



---

## Settings

### Sound and Alert Settings

#### Adjust the Ring Volume



**NOTE:** An intrinsically safe handset's ring volume is lower than a non-intrinsically safe handset's ring volume due to current limitations.

1. Enter the menu by pressing "Menu".
2. Select   in the menu.
3. Select "Sound & Alerts".
4. Select "Volume".



**Note:** Step with > to increase the volume and with < to decrease it. Press "Back" to save the setting. If a handset restriction is enabled, it might not be possible to set the ring signal to Silent. See the handset's Configuration Manual for more information.

#### Set different Ring Signals for Calls

**NOTE:** If the parameter Force stimuli ringing is enabled, the handset uses the system-provided ring signals instead of the local ring signals. See the Configuration Manual for the Avaya 374x Handsets. This function is applicable in legacy systems only (stimuli).

1. Enter the menu by pressing "Menu".
2. Select   in the menu.
3. Select "Sound & Alerts".
4. Select "Ring signals".
5. Different signals for internal calls, external calls and call back can be set. Select "Internal call", "External call", "Callback, or "Priority call". The handset has 14 different ring signals. Select sound. By pressing "Play" it is possible to listen to the different sounds.
6. Press "Back".

#### Set Alert for Messages

1. Enter the menu by pressing "Menu".
2. Select   in the menu.
3. Select "Sound & Alerts".
4. Select "Message alert".

5. Select the wanted message alert from the list. By pressing "Play" it is possible to listen to the different alerts.
6. NOTE: The "Play" soft key is not available for Enhanced beep. Instead, send a message to the handset to listen to the sound.
7. Press "Back".

**Tip:**

By default, the message volume follows the ring volume setting, but it is possible to set another message volume in the handset. See the handset's Configuration Manual for more information.



### Turn the Vibrator On and Off

If the vibrator is activated, the handset vibrates on incoming calls and messages.

**Tip:**



The handset vibrator can also be activated when receiving a message during a call via PDM/Device Manager. See the handset's Configuration Manual.

**NOTE:** When the vibrator is enabled on an intrinsically safe handset, the handset alternates between vibration and sound. That is, vibration and sound are not activated simultaneously.

1. Enter the menu by pressing "Menu".
2. Select   in the menu.
3. Select "Sound & Alerts".
4. Select "Vibrator alert".
5. Select "On", "On if silent" (that is, the vibrator is on when the handset is muted), or "Off".
6. Press "Back".

### Set the Key Sound

This means that every time a key is used, the handset emits a small sound.

1. Enter the menu by pressing "Menu".
2. Select   in the menu.
3. Select "Sound & Alerts".
4. Select "Key sound".
5. Select "Silent", "Click", or "Tone".  
It is possible to listen to the key sound by pressing "Play".
6. Press "Back".

## Keypad Lock Settings

The handset keypad can be locked automatically to minimize the risk of accidentally pressing keys or buttons while the handset is not in use. The keypad is automatically locked after a lock time parameter "Auto lock time" expires.

**NOTE:** The alarm button can be pressed while the keypad is locked. Any one of five predefined emergency numbers can also be called while the keypad is locked as long as this feature has been configured in the PDM/Device Manager. For additional information, see the Configuration Manual for the handset.

The automatic key lock can be configured by the administrator in the PDM/Device Manager. For additional information, see the Configuration Manual for the handset. The user may also configure the automatic key lock as described in the following sections.

Automatic key lock: One of the following options may be configured:

"On": the keypad is automatically locked if it is not used before the specified lock time elapses.

"On, except calls": the keypad is automatically locked if it is not used for the specified lock time. If the user is in call when the lock time elapses, the keypad remains unlocked until the user has completed the call.



"Off": the keypad is never automatically locked.

Auto lock time: specifies the time that elapses before the keypad is automatically locked. The shortest time that may be specified before the key lock is applied is 5 seconds and the longest time is 3 minutes.

Auto key unlock: the keypad is automatically unlocked when a call or message is received. When the user has serviced the call or message, the key lock is reapplied after the specified automatic lock time expires.

### Activate the Automatic Key Lock

The user activates the automatic key lock and sets the Auto lock time from the handset "Settings" menu in the following way:

1. Enter the menu by pressing "Menu".
2. Select   in the menu.
3. Select "Locks". The "Locks" menu is displayed.
4. Select "Automatic key lock" menu item and select "On" or "On except calls".
5. NOTE: The current key lock setting is displayed under the "Automatic key lock" menu item.
6. Press the "Back" soft key to redisplay the "Locks" menu.
7. Select "Auto lock time" and press the "Select" soft key.
8. Select the required lock time and press the "Select" soft key.



**NOTE:** The alarm button can be pressed while the keypad is locked. Any one of five predefined emergency numbers can also be called while the keypad is locked as long as this feature has been configured in the PDM/Device Manager. For additional information, see the handset Configuration Manual.

**NOTE:** A call can be answered or ended while the keypad is locked.

**NOTE:** A call can be answered or ended while the keypad is locked. If the handset is configured via the PDM/AIWS2, any one of five predefined emergency number can be called while the keypad is locked

Additionally, if the Multifunction button (3740 only) is configured as a shortcut to a predefined number, it can also be used while the keypad is locked. See handset Configuration Manual.

### Deactivate the Automatic Key lock

1. Enter the menu by pressing "Menu".
2. Select   in the menu.
3. Select "Locks".
4. Select "Automatic key lock".
5. Select "Off" to deactivate the automatic key lock.

## Phone Lock Settings

The handset can be protected for unauthorized use by activating the phone lock. The phone lock may be set to:

- "On": The handset is automatically locked if not used for the specified automatic lock time or when it is first turned on.
- "On in charger": The handset is locked immediately when placed in the charger. When removed from the charger and unlocked by the PIN, the handset remains unlocked
- "Off": The handset is never locked.



The default phone lock PIN code (0000) can be changed to any 4 to 8 digit personalized code.

The length of time before the handset locks automatically is set by the "Auto lock time" parameter. The shortest time that can be set before the handset locks is 5 seconds and the longest time is 3 minutes.

**NOTE:** If configured in the handset, any one of five predefined emergency numbers can be called while the handset is locked. Additionally, the Multifunction button (3740) or Alarm button (3745/3749) can also be used while the handset is locked. If the multi-function button is used in this way, it can only call a predefined number configured via the PDM/AIWS2. See the handset Configuration Manual.



### Activate the Phone Lock

The phone lock settings are activated from the handset "Settings" menu in the following way:



1. Enter the menu by pressing "Menu".
2. Select   in the menu.
3. Select "Locks".
4. Select "Phone lock".
5. Select "Auto phone lock".
6. Select "On" or "On in charger" as required.
7. Enter PIN code.
8. Press "OK".
9. Press the "Back" soft key twice to return to the "Locks".
10. Select "Auto lock time".
11. Select the required lock time.

If the PIN code is forgotten it can be removed by your distributor.

### **Deactivate the Phone Lock**

1. Enter the menu by pressing "Menu".
2. Select   in the menu.
3. Select "Locks".
4. Select "Auto phone lock".
5. Select "Off".
6. Enter PIN code
7. Press "OK".  
If the PIN code is forgotten it can be removed by your distributor.

### **Change PIN Code**

1. Enter the menu by pressing "Menu".
2. Select   in the menu.
3. Select "Locks".
4. Select "Phone lock".
5. Select "Change PIN code".
6. Enter the old PIN code.
7. Press "OK".
8. Enter the new PIN code.
9. Press "OK" and enter the new PIN code again.
10. Press "Save".



## Display Settings

### Screen Saver

The screen saver can be set to one of the following settings:

- Information: Displays status and identification information while the handset is idle.
- Black: The screen is black when the handset is idle.
- Black also in call: The screen is also black when the handset is in call.



To set the screen saver:

- Enter the menu by pressing "Menu".
- Select   in the menu.
- Select "Display".
- Select "Screen saver".
- Select "Information", "Black", or "Black also in call".
- Press "Back".

When the handset is in a CR3 charging rack, the owner ID and the variant of the handset are displayed. This simplifies identification when many handsets are charged together.

### Brightness



**NOTE:** An intrinsically safe handset's display brightness is lower than a non-intrinsically safe handset's display brightness due to current limitations.

1. Enter the menu by pressing "Menu".
2. Select   in the menu.
3. Select "Display".
4. Select "Brightness".
5. Select "Normal" or "Power save".

**Note:** When the phone is in "Power save" and the user goes to the device information section, the screens have been set to use normal brightness to improve readability when identifying the software versions and IDs of the phones.

6. Press "Back".

### Contrast

1. Enter the menu by pressing "Menu".
2. Select   in the menu.
3. Select "Display".

4. Select "Contrast".
5. Step with > to increase and < to decrease the contrast.
6. Press "Back".



## Time and Date Settings

The time and date displayed in the handset cannot be changed by the user. The DECT system is solely responsible for keeping the time. The handset also synchronises with the DECT system time when:



- The handset is turned on after having been turned off. The handset requests the current DECT system date and time.
- The handset remains on for longer than 24 hours. The handset requests the DECT system time every 24 hours from the time it was last turned on.

The time and date formats displayed in the handset can be changed by the user as described in the following sections.

### Set Time Format

1. Enter the menu by pressing "Menu".
2. Select   in the menu.
3. Select "Time & Date".
4. Press "Select".
5. Select Time format. The actual time format is displayed. Selectable time format:
  - 12:00 (AM/PM)
  - 24:00
6. Press "Select" to save the setting.


### Set Date Format

1. Enter the menu by pressing "Menu".
2. Select   in the menu.
3. Select "Time & Date".
4. Press "Select".
5. Select "Date format", press "Select". Selectable date format:
  - DD MMM YY, for example 30 Jan 11
  - MMM DD YYYY, for example Jan 30 2011
  - YYYY-MM-DD, for example 2011-01-30 (ISO 8601)
  - MM/DD/YYYY, for example. 01/30/2011 (also called US)






- DD/MM/YYYY, for example 10/01/2011 (also called Europe)
  - DD-MM-YYYY, for example 30-01-2011
  - DD.MM.YYYY, for example. 30.01.2011
6. Press "Select" to save the setting.

## Answering



The default setting for the handset is to use  when answering a call. The answering behaviour can be configured to answer the call automatically, that is, without pressing a key, or/and in loudspeaking mode.

**Note:** When Bluetooth is enabled, the loudspeaker audio is lowered due to current limitations in the intrinsically safe handset.



The answering behaviour can also be set to any key. If "Any key" is selected, any key except , , and  can be used to answer a call.

### Answering Key



The answering key is by default set to Hook-off.

1. Enter the menu by pressing "Menu".
2. Select   in the menu.
3. Select "Answering".
4. Select "Answering key".
5. Select "Hook-off", or "Any key".
6. Press "Back" to save the settings.



### Answering Behaviour

1. Enter the menu by pressing "Menu".
2. Select   in the menu.
3. Select "Answering".
4. Select "Answer behaviour".
5. Select "Automatically" or "Loudspeaking".
6. Press "Change" to change the setting. The check box is marked.
7. Press "Back" to save the setting. To remove the setting, press "Change". The check box is unmarked.

## Change Text size for Messages

1. Enter the menu by pressing "Menu".
2. Select   in the menu.
3. Select "Messages".
4. Select "Text size Normal". The default text size is "Normal".
5. Select "Normal" or "Large" size.
6. Press "Back".

## Change the Menu Language

1. Enter the menu by pressing "Menu".
2. Select   in the menu.
3. Select "\*Language".
4. Select the language to be used.
5. Press "Back".





### Tip:

It is also possible to download an additional language to the handset, see [Software Upgrade and Additional Features](#) on page 115.

## Change Owner ID

The Owner ID is set to identify the handset.

1. Enter the menu by pressing "Menu".
2. Select   in the menu.
3. Select "Owner ID".
4. Enter name/identity. See [Alphanumeric keys](#) on page 37.
5. Press "Save".

## Alarm Settings




### Tip:

It is recommended to configure a shortcut to this menu if it is frequently used, see [Short cuts](#) on page 87.

## Edit Alarm Data


**NOTE:** This menu is not applicable for 3740.

Information (for example a handset's location) can be sent along with an alarm. It is recommended to create a shortcut for quick access to the "Edit alarm data" menu, see [Shortcuts](#) on page 87.

1. Enter the menu by pressing "Menu".
2. Select  in the menu.
3. Select "Alarm".
4. Select "Edit alarm data".
5. Enter alarm data.
6. Press "Save".

## Activate alarm

**NOTE:** This menu is applicable for 3749 only.

1. Enter the menu by pressing "Menu".
2. Select  in the menu.
3. Select "Alarm".
4. Select "Activate alarm".
5. Select "Man-down", and/or "No-movement".
6. Press "Select" to change the setting. The check box is marked.
7. Press "Back" to save the setting. To remove the setting, press "Select". The check box is unmarked.

When an alarm is activated, the corresponding alarm icon is show, see Table 7 on page 99.



	Man-down alarm
	No-movement alarm

Table 7. Alarms icons


---

# Alarm Operations for 3749 telephones

**Note:** The alarm settings described in this chapter can only be configured in PDM or AIWS.


---

## Push-Button Alarm

The push-button  can be defined to send an alarm by a long press and by multiple press. By default, long press is defined for test alarm (see [Test Alarm](#) on page 100), and multiple press is defined for personal alarm (see [Personal Alarm](#) on page 100).

---

## Test Alarm

Press and hold the push-button  until the dialog window Test Alarm (default) is displayed.


Depending on set parameters, following occur:

- A beep is heard.
- The orange LED flashes twice.
- The vibrator stirs.
- The telephone receives a notification that the alarm has been received by the system. This is a system dependent feature.
- An acoustic location signal (ALS) is played. See [Acoustic Location Signal](#) on page 101.
- A call to a predefined number is established. See [Automatic Call after Alarm](#) on page 102.

**Note:** When the vibrator is enabled, the telephone will alternate between vibration and sound. That is, vibration and sound are not activated simultaneously. The ALS will no be played if the Automatic call after alarm option is enabled.

---

## Personal Alarm

Press the push-button  twice or more, the dialog window Personal Alarm (default) is displayed. Depending on set parameters, following occur:

- A beep is heard.
- The orange LED flashes twice.
- The vibrator stirs.

- The telephone receives a notification that the alarm has been received by the system. This is a system dependent feature.
- An ALS is played. See [Acoustic Location Signal](#) on page 101.
- A call to a predefined number is established, see [Automatic Call after Alarm](#) on page 102.

**Note:** When the vibrator is enabled, the telephone will alternate between vibration and sound. That is, vibration and sound are not activated simultaneously. The ALS will no be played if the Automatic call after alarm option is enabled.

---

## Man-Down and No-Movement Alarm

Man-down alarm: If the telephone is tilted 45° (default) or more for a preset time (default 7 seconds), the Man-down alarm is triggered.

No-movement alarm: If no movement is detected during a preset time (default 30 seconds), the No-movement alarm is triggered.

When an alarm is triggered, the following occur depending on the settings:

- A dialog window "Man-down warning. Cancel?" or "No- movement warning. Cancel?" is shown in the display, and a warning tone is also played for a period (default 7 seconds) before the alarm is sent.
- To prevent the alarm from being sent and to silence the warning tone, do one of the following:
  - Press any key or button. The alarm is reset.
  - Put the telephone in a charger. The alarm is temporarily disabled, and the corresponding alarm icon is hidden. The alarm is enabled when you remove the telephone from the charger.
- If no key or button is pressed during the warning tone, the alarm is sent. Depending on set parameters, a beep, vibrator, or LED signal confirms that the alarm has been sent.
- An ALS may be activated after the alarm has been sent. See [Acoustic Location Signal](#) on page 101.
- A call to a predefined number is established. See [Automatic Call after Alarm](#) on page 102.

---

## Acoustic Location Signal


Depending on set parameters, the ramped up ALS is played after an alarm. The signal is always ramped from the lowest volume to the highest. Press  to turn the ALS off.

Depending on the PDM settings, it is possible to make the user enter a password when turning the ALS off. This password is the same as the phone lock password.

ALS is configurable for Man-down and No-movement alarm and Push-button alarm.

---

## Automatic Call after Alarm

A telephone can be configured to call a predefined number after an alarm has been sent. If configured, it is also possible to call the predefined number without sending an alarm by pressing the push-button . Depending on the settings, the call can be established in the following modes:

- Loudspeaking mode
- Normal mode

**Note:** When Bluetooth is enabled, the loudspeaker audio is lowered due to current limitations in the intrinsically safe 3749 telephone.



---

## Connections

### Bluetooth

**NOTE:** Bluetooth is not applicable for 3740.


#### Enable Bluetooth Connection

1. Enter the menu by pressing "Menu".
2. Select  in the menu.
3. Select "Bluetooth".
4. Select "Enable". A Bluetooth connection icon  is displayed in the header bar.

**NOTE:** When enabling Bluetooth on an intrinsically safe handset, it is restarted.

**Note:** When enabling Bluetooth on 3745 handsets, it is not restarted.


#### Disable Bluetooth Connection


1. Enter the menu by pressing "Menu".
2. Select  in the menu.
3. Select "Bluetooth".
4. Select "Disable".


**NOTE:** When disabling Bluetooth on an intrinsically safe handset, it is restarted.

**Note:** When disabling Bluetooth on 3745 handsets, it is NOT restarted.

## Pair/Connect Bluetooth Headset

To be able to use a Bluetooth headset, it must first be paired with the handset. It is only needed to pair the Bluetooth headset once. A paired Bluetooth headset is automatically connected, as indicated by the icon  in front of the headset.



1. Set the Bluetooth headset in pairing mode, see the user manual for the Bluetooth headset.
2. Enable Bluetooth, see *Enable Bluetooth Connection*.
3. Enter the menu by pressing "Menu".
4. Select  in the menu.
5. Select "Bluetooth".
6. Select "Headset".
7. Select "Add new". A Put headset in Pairing mode dialog window is displayed.
8. Press "OK". It now searches for a Bluetooth headset for connection.
9. When headset is found, press "Pair".
10. If needed, enter PIN code, see user manual for the Bluetooth headset. Press "OK".

The dialog Successful pairing appears if the pairing process was successful. The Bluetooth headset is also connected as indicated by the icon  in front of the headset.

## Headset

To achieve optimal audio quality with the different headset types, it is recommended to select the corresponding headset type.

The default setting is microphone on a boom, that is, the audio is optimized for using a headset with microphone on a boom. The headset type can be changed in the menu by doing as follows:

1. Enter the menu by pressing "Menu".
2. Select   in the menu.
3. Select "Headset".
4. Select the corresponding headset type from list, that is, "Mic on boom", or "Hearing protection". Additional headsets<sup>1</sup> might be visible in the list.
5. Press "Select".

**NOTE:** When Bluetooth is disabled and having an active call in loudspeaker mode on an intrinsically safe handset, the audio is not transferred to the headset when connecting it.

1. Only visible if a headset profile has been configured in the PDM/Device Manager.

**Important:**

The headset Microphone on a boom is not available as accessory for the intrinsically classified handset. If used, it is NOT permitted to use the headset in hazardous areas.

## System

The handset can subscribe up to eight different systems.

### Change System



Select "Automatic" or a specific system. If the handset is set to "Automatic", it selects a system according to the priority list, see [Priority](#) on page 105.

**NOTE:** "Automatically" cannot be used in both legacy and IP-DECT systems.

### Subscribe Handset in DECT System

To subscribe an DECT system manually, the "Park:" (Portable Access Right Key) and "Ac:" (Authentication code) related to the system are needed. Contact the system administrator for more information.

**NOTE:** The PARK code may not be needed if there is no alien DECT system within the coverage area.



1. Enter the menu by pressing "Menu".
2. Select   in the menu.
3. Select "System".
4. Select "Subscribe".
5. The handset's IPDI is displayed. The IPDI is a unique code that has been assigned to the handset. Press "Next".
6. Enter System name (optional). If no system name is entered, the default name is used. That is System A, System B etc. depending on which system name that is free.
7. Note: The System name might not be displayed depending on the handset's Display Management Layout setting. See the handset's Configuration Manual.
8. Press "Next".
9. Enter PARK code (max. 31 digits). The PARK code may not be needed if there is no alien DECT system within the coverage area.
10. Enter AC code. The AC code length must be between 4 - 8 digits.
11. Press "Next".
12. An information text "Protection on?" is displayed. Select "Yes" if the new system is to be protected.



**NOTE:** It is not possible to unsubscribe a protected system via the System menu. The unsubscription must be made via the Admin menu or the DECT system.



13. Press "OK". A searching mode starts.

### Unsubscribe System

1. Enter the menu by pressing "Menu".
2. Select   in the menu.
3. Select "System".
4. Select "Unsubscribe".
5. Select the system to unsubscribe.
6. Press "Yes to unsubscribe the system."

### Rename System



It is possible to change the name of the system in the handset.

1. Enter the menu by pressing the "Menu" soft key.
2. Select   in the menu.
3. Select "System".
4. Select "Rename System".
5. Select system to rename.
6. Enter new name.
7. Select "Save".

### Priority

The default order of priority is the order of entered subscriptions. This means that the first subscribed system has the highest priority. This list can be edited by the user. It is possible to set the systems in priority by moving them up or down in the list.

**NOTE:** This is used in combination with system set to be "Automatic", see [Change System](#) on page 104.

1. Enter the menu by pressing "Menu".
2. Select   in the menu.
3. Select "System".
4. Select "Priority".
5. Change the priority if needed by selecting "Up" or "Down". The priority is saved when "Back" is selected.



## In Charger Action when in Call

It is possible to determine actions to be performed when a handset is placed in charger during a call.

1. Enter the menu by pressing "Menu".
2. Select in the menu.
3. Select "In charger".
4. Select "Call behavior".
5. Select one of the following:
  - No action - no action is performed when handset is placed in charger during a call.
  - Loudspeaking - The loudspeaker is activated when handset is placed in charger during a call.
  - End call - The call is disconnected when handset is placed in charger.

## In Charger Action when not in Call

It is possible to determine actions to be performed when a handset is not in call and placed in charger.

1. Additional In charger actions can also be configured, see the handset's Configuration Manual.
2. Enter the menu by pressing "Menu".
3. Select   in the menu.
4. Select "In charger".
5. Select "Other actions".
6. Select one of the following:
  - No action - no action is performed when handset is not in call and placed in charger.
  - Switch off - When the handset is placed in the charger it will switch off. When it is removed from the charger it will switch on again.
  - Sound off<sup>1</sup> - The handset is muted when placed in the charger. When it is removed from the charger it switches on the sound again. NOTE: Messages with breakthrough, for example high or alarm priority, is not muted.
  - Redirect - Calls can be redirected to another extension when the handset is placed in a charger. This function must be programmed in the PBX to be able to redirect calls.

1. If the parameter Possible to turn off sound is set to "No" in PDM/Device Manager, the handset is not muted in charger.

- Change profile - when the handset is placed in the charger it changes profile. When the handset is removed from the charger, the profile is changed back.

Press "Edit" and select the wanted profile. By default only the profile Normal is visible, but additional profiles is visible if they are configured. See [Profiles](#) on page 42

**Note:** Message absence - When an application or system sends a message to a handset, it receives an indication that the handset is absent. If a handset is absent, the application or system determines if the message are sent to the handset or not, or redirected to another handset.

If a message is sent from a handset, it does not receive an indication that the recipient is absent. This function must be programmed in the PBX to be able to redirect calls/messages.

---

## Procedure Call



When configuring the functions Call services, In Call menu, Contacts, or a shortcut/service to the Phone call function, the data added in these functions is static. When entering the data for the function to be used, it is possible to add a variable/character U that allows the user to enter additional numerical characters before calling the number/sending the data to a system.

See the following example for more information.

Example of configuration:

A user wants to create a service with the Phone call function. The PBX requires that a prefix must be added to a phone number. In this case, the user can pre-program the prefix and then enter the applicable phone number when using the Phone call function.

1. Press "Menu", or the confirmation button.
2. Select "Services""My Favourites".
3. Select "Add new".
4. In the Name field, enter "Call no.".
5. Select the function "Phone call".
6. In the Number field, enter the prefix to be used followed by the character "U". In this case, the text string is as follows \*21\*U. The character U represents an Enter number dialog where the user can enter the phone number.
7. Press "Save".

When using the function, an Enter number dialog appears, see figure below. If the user enters "123" (or selects a contact with this number by pressing   ) and presses "OK", the number \*21\*123 is dialed. Note that no call is established before the user presses "OK", that is, post-dial.

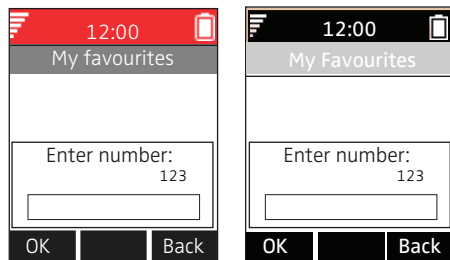


Figure 8. Enter number dialog.

**Note:** Using a shortcut to make a procedure call is not supported while the handset is locked.

---

## Advanced Functions

---

### Admin menu

The system administrators can use the hidden menu in the telephone for administration. See also *Installation and Administration Manual, IP DECT*.

The Admin menu contains:

- Software, hardware, IPEI/IPDI, and user ID (Messaging ID might also be shown)
- DECT information
- Centralized Management showing online information
- Site Survey Tool for indication of radio signal and base station listing
- Fault logging
- Frequency band selection
- System menu with ability to alter protection
- Factory reset option

To activate the Admin Menu, enter Settings > Device info > Software and press the buttons containing CRAFT#, that is "27238#".

For quick access to the Device Information (DI) menu in idle mode, press the keys containing \*#DI# (that is \*#34#). For quick access to IPEI/IPDI, press \*#06# in idle mode. See the table below.

Information	Code
Software version	*#34#
Hardware version	*#34#
IPEI/IPDI	*#34# or *#06#
User ID	*#34#

---

### Clearing lists in charger

You can set a parameter through the PDM or AIWS to clear messaging lists and call lists that has been stored in the cordless telephone. When the parameter is activated and the function has been downloaded to the cordless telephone, the lists are deleted when placed in a charger. This feature can be useful during administration of cordless telephones for new users. See also *Installation and Administration Manual, IP DECT*.

---

## Enhanced Messaging

**NOTE:** The following enhanced messaging features are not applicable for 3740.

---


### Receive a Message with Request for Answer

In the status bar, a message with request for answer is indicated the same way as an ordinary message, see [Messaging](#) on page 43.

In the message list, the message with request for answer is indicated by the icon .

### Accept/Reject the message

Press the soft key “Accept” or “Reject”.

When an acknowledged message has been replied to, the icon  is shown in the message list. The text “Accepted” or “Rejected”, and time and date is also added in the acknowledged message.

**NOTE:** The option “Delete” is not available for a message with request for answer. An unacknowledged message can only be deleted from the message list.

---

### Message Queuing and Message Priority

To notify about new incoming messages, all incoming messages are placed in a message queue. The sorting order for the message queue depends on the system settings. By default the messages are sorted according to message priority, and thereafter according to arrival time.

The messages in the message queue are automatically displayed for 20 seconds until all messages have been displayed. You can extend the time to display a message by pressing any button. You can also close a message to immediately see the next message in the message queue.

The messages that you do not close are put last in the message queue and remain in the message queue until you close them. They are shown as unread in the message list and will not be shown as read until you have closed them.

See the Configuration Manual, Avaya 374x Handsets, TD 92657EN for more information on how to set the parameters.

---

## Message Priority and Call Priority

The default setting is that the call information dialog is always visible in front of a message on incoming calls. A message with a certain priority can be configured to ensure that it is always displayed without being interrupted by a call. By setting a call priority, the handset compares the call priority with the message priority to determine which information to be displayed, that is, the call information dialog or the message. If the message priority and the call priority are equal, the message is displayed.

See the handset's Configuration Manual for more information how to set the parameters.

---

## Message Indication Repetition

By default, when a new message is received or displayed, the LED starts flashing green once and the message alert signal sounds. It is possible to configure the handset to repeat the alert signal for an unread message every 7th second as long it is displayed. See the handset's Configuration Manual for message settings.

Priority 1 messages with certain system-defined properties are handled as extra important and therefore will the alert signal be repeated every 10th second in 5 minutes, or until any key is pressed. Note that this is a system/application dependent feature and cannot be configured in the handset.

---

## Color Messaging

It is possible to send colored messages to handsets. The sender of a message (that is, an application) determines the color of the message. Colored messaging can be useful for categorizing messages. In [figure 9](#) on page 112, there are two colored messages (a new message, and a read message) in the message inbox (left in the figure). The messages are indicated by a gradient colour bar behind the envelopes. In addition, a gradient color bar is shown below the envelop when reading a colored message (right in the figure).

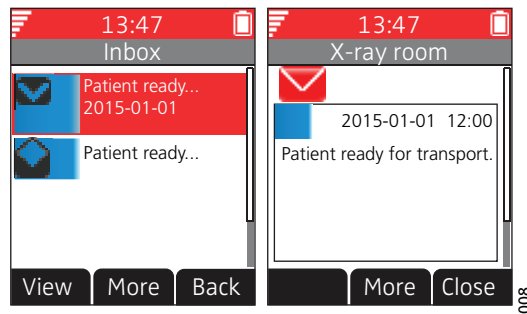


Figure 9. Shows examples of color messages.

## Interactive Messaging

Interactive Messaging (IM) is a function that extends basic messaging. It makes it possible for a user of a handset to access information from a client application in the system.

An example can be a customized application that can be accessed from the handset. A list of actions can be included in the message sent from the application (for example AMS or XGate) to the handset.

By default, an IM is indicated and viewed the same way as an ordinary message, see [Messaging](#) on page 43. It is saved along with other messages in the message list.

**NOTE:** The indication of an IM can differ from an ordinary message depending on the settings in the IM. The application that sends the IM can determine the alert signal volume and LED indication.

When an IM has been read, the IM may display several options.

1. Press "More" to open up a list of available options.
2. Mark an appropriate option in the list.
3. Press "Select".
4. If the selected option requests input, enter the information needed and press "Ok". A press on the middle Soft key will change to digit or text input mode depending on if it is digit or text format in the message.

A read message is indicated the same way as an ordinary message.

**NOTE:** If a handset receives an IM update when the original message already has been deleted, the handset automatically sends a negative acknowledge (NAK) to the system, if requested.

For an example of an interactive message, see [figure 10](#) on page 113. The options depend on the configuration in the client application.



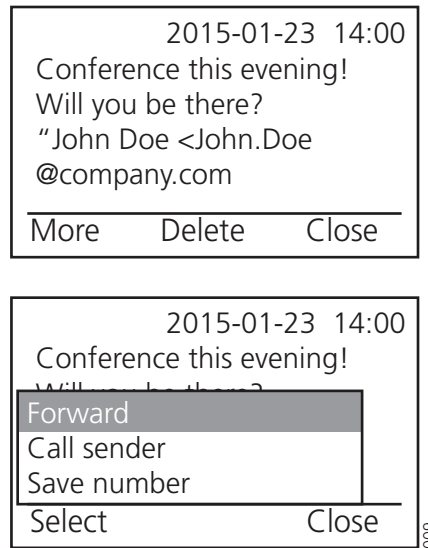


Figure 10. Example of an Interactive Message.

Mobile data from the handset can initiate the application to send the interactive message, see [Mobile Data](#) on page 114. The user can then select one action from the list. The action can be sending a message back to the application and/or dialling a specific number etc.

---

## Message Templates

Predefined messages contained in message templates can be used in a number of different situations to quickly construct a message rather than having to construct the message completely from scratch.

Up to five predefined messages can be configured for the handset in the PDM/Device Manager. This lets the user select and send a message appropriate to the current situation, such as "I am in a meeting" or "I am in the operating theatre".

How to use the PDM/Device Manager to create store predefined messages the handset is described in the Message Templates section of the handset configuration manual.

Before a message is sent, the user may edit, add, or remove text from the message. For example, the message "I am in a meeting" could be appended with " - please call back after 1500".

The message template function can be used in the following contexts:

- When a call is received that the user wishes to decline, but still acknowledge with a message, without having to type a completely new message. See [Declining a Call with a Predefined Message](#) on page 63.

- When a text message is received that the user wishes to answer with a text message without having to type a completely new message. See [Answering a Text Message with a Predefined Message](#) on page 114.
- When the user is writing a message using the handset Messaging function without having to type a completely new message. See [Writing new messages](#) on page 82.

## The Templates Menu

To access a template and use it in one of the ways described above, perform the following steps:

1. Open the "Templates" menu as described in the context in which the template is being used.
2. Select the required message from the "Templates" menu.
3. To edit the message, use the handset navigation key to move to different parts of the message, the handset key pad to add additional text, and the "Clear" soft key to delete unwanted text

## Answering a Text Message with a Predefined Message

To respond to an incoming text message with a predefined message, perform the following steps:

1. Press the soft key "Reply"
2. Press the "More" soft key. The "Templates" option is displayed.
3. Press the soft key "Select". A list of predefined message templates is displayed.
4. Navigate to the required message template and press the "Select" soft key. If required, edit the message as described in [The Templates Menu](#) on page 114.
5. Press the soft key "Send". The message sender's number is displayed in the handset display.
6. Press the soft key "Send". A "Message sent" confirmation is displayed and the message is sent to the caller.

---

## Mobile Data

### Send Mobile Data

Predefined data can be sent from the handset by selecting a Service, see [My favourites](#) on page 44. In addition, a shortcut can be created for quick access to a Service, see [Short cuts](#) on page 87.

Mobile data can be used for opening a door, starting/stopping a machine etc.

## Send Mobile Data with a Prefix

Mobile data with a prefix is sent from the handset by pressing a pre-programmed Hot key or Soft key or select a Service. Mobile data with prefix can be used to send information to an application in the system.

The prefix is predefined by the user when programming the Service, see [My favourites](#) on page 44.

---

# System handling

---

## Software Upgrade and Additional Features

Software and parameters in the handset can be upgraded by using the PDM/Device Manager. Examples of additional features that can be downloaded/configured via PDM/Device Manager:


- Local phonebook
- Company phonebook
- Downloadable languages
- Customizing the Menu Tree

Refer to the handset's Configuration Manual.

To view the handset's software version, enter `*#34#` in idle mode.

---

## Handset Updates via Charging Rack

From time to time, users are instructed to leave their handsets in a central charging rack to allow the handset to be updated with new features and functions. An ongoing update is indicated by  in the handset display and an "Updating handset" message is displayed in the active area.

During the update, a message is displayed to indicate that an update is in progress as shown in [figure 11](#). The "OK" soft key can be selected to close the message.

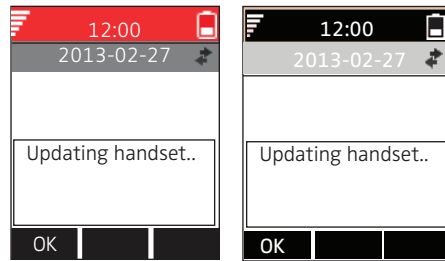
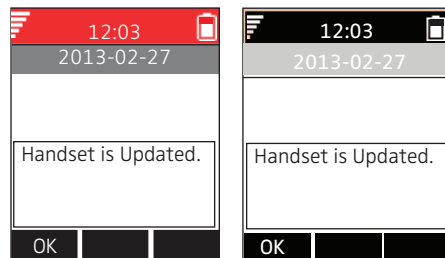


Figure 11. Handset Update while in Charger

If the handset removed from the charger and used, the update is suspended and resumed when it is returned to the charger.

When the update is complete, a "Handset is updated" message is displayed to indicate that the handset is available for use, as shown in [figure](#) . Select the "OK" soft key to close the message.



Update Completed while in Charger

---

## Troubleshooting

This section contains information on how to solve common operational problems, and warnings you may receive.

Go through the following lists if you encounter any problems. If this checklist does not solve the problem, contact your system administrator.

If others have similar problems, there may be a system error.

## Operational Problems

Fault	Probable cause	Action or comment
No display	The battery level is low or the handset is defective.	Charge the battery or contact system administrator.  Change the screen saver setting as described in <a href="#">Screen Saver</a> on page 95.
No ringing	The sound off icon is on, or ringer volume set to silent, or the handset is defective.	Long press the Sound off key, or increase volume, or contact system administrator.
No change in time & date setting	PBX dependent.	Changes in the handset appear after a maximum of 24 hours after a change in the system or by turning the handset off and on again.
Cannot mute handset by long pressing Sound off key/Mute button.	A handset restriction preventing the user to silence the handset.	Enable the parameter Possible to turn off sound, see the handset's Configuration Manual.
Not possible to set the ring volume to "Silent".		
Handset, with In Charger > Other actions > Sound off enabled, is not muted when placed in charger.		
Cannot switch off handset by long pressing the On-hook key.	A handset restriction preventing the user to switch off the handset.	Enable the parameter Possible to switch off handset, see the handset's Configuration Manual.
Handset, with In Charger > Other actions> Switch off enabled, is not switched off when placed in charger.		

## Error or Warning Messages

Display shows	Probable cause	Action or comment
---------------	----------------	-------------------

No access	The network is in range, but no access rights.	Switch handset off and then switch it on again or contact system administrator.
No System. The handset beeps once a minute (during max 30 minutes) with a low tone followed by a high tone (if enabled, the vibrator also follows the beeps).	The handset is out of coverage or handset is defective.	Stop the beep with the Sound off key and go into range. Note: When re-entering the coverage area it can take a couple of minutes before the handset automatically has registered into the system. or contact system administrator.
No flash driver was found <b>Note:</b> This display message is only shown in English.	Failed to read from flash	Send the handset for service.
SERVICE NEEDED Hardware error <b>Note:</b> This display message is only shown in English.	There is a communication problem between components in the handset.	Restart the handset. If the problem persists, send the handset for service.
SERVICE NEEDED Invalid IPDI <b>Note:</b> This display message is only shown in English.	Easy replacement procedure not followed correctly or failure during easy replacement procedure.	Send the handset for service.
SERVICE NEEDED Parameters corrupt. <b>Note:</b> This display message is only shown in English.	The handset is defective.	Select reset option on the middle soft key if available or if no reset option is available or fault does not resolve the handset needs repair. Note: Display message only shown in English.
Enter PIN code	The handset's lock is activated.	Enter the required PIN code. If PIN code lost enter new via PDM/Device Manager or do a factory reset via PDM/Device Manager.
Battery low, charge now	The battery level is low.	Charge or replace the battery.
Phonebook is not available at the moment.	The phonebook does not respond, not available at the moment.	Try again later or if fault persists do a factory reset via admin menu or PDM/Device Manager.

Voice mail number not defined	There is no Voice mail number defined in the handset.	Define a Voice mail number via PDM/Device Manager.
Could not encrypt connection	The parameter "Encryption Required" is enabled in the handset in combination with;	
	1) Unencrypted base station(s); and/or,	1) Disable the "Encryption required" parameter in handset via PDM/Device Manager; and/or,
	2) Unsupported base station(s).	2) Enable the encryption in the base station(s); and/or,
		3) Use supported base station(s). Ask your supplier.
Not allowed	1) The user cannot login to the handset with the shared phone functionality enabled, due to another handset currently using the same extension (User).	1) Logout from the handset that uses the same extension.
	2) The user cannot logout from the handset with the shared phone functionality enabled, due to incorrect password (AC code).	2) Enter #11*<AC code># on the keypad and press the off-hook key to logout from the shared phone.
	3) The extension (User) does not exist.	3) Make sure that you entered correct extension. If needed, contact the system administrator.
	4) The password is not correct.	4) Make sure that you have entered correct password. Ask the system administrator if you have forgot the password.

## LED Error Indications

See also chapter [LED Indications during Easy Replacement](#) on page 127.

LED is flashing red, quick flash, (100 ms on, 800 ms off)

1. 1) If a third handset, that is another handset other than the old replaced handset or new replacement handset, is inserted into the charger during Easy Replacement, this error indication appears. Replace the correct handset.



2. 2) The charger has found that Easy Replacement does not work. Change back to the new handset.

LED is flashing red, long flash (800 ms on, 100 ms off)

Error during Easy Replacement. Both handsets need to be sent for service.

---

## Operation Notice

---

### Accessibility and voice quality



The base network is not always available. If you do not get in contact with your system, contact your system administrator. For best voice quality, avoid positioning near computer, radio or similar equipment.

### Operating area

You can only use your cordless telephone in the area that is covered by your system. Outside this area, you will loose contact with the system. The signal strength icon will be low and **Searching** text will be displayed.

### Out of Range

When you leave the system's coverage area a short beep will sound and the text "Searching" will appear in the display.

The out of range beep is repeated every minute for 30 minutes. The sound can be turned off by long pressing, , or .

**NOTE:** If handset restriction is enabled, it might not be possible to turn the sound off. See the handset's Configuration Manual.

When re-entering the coverage area it can take a couple of minutes before the handset automatically has registered into the system.


---

# Maintenance


---

## Maintenance of Batteries



### Battery Warnings

 The "Low battery" icon is displayed when the battery has 10% or less remaining capacity left. In addition; a warning signal sounds every minute, the LED flashing orange, and the dialog window "Battery low. Charge now." appears.





 The "Empty battery" icon is flashing when the battery has 5% or less remaining capacity left. In addition; a warning signal sounds every second, the LED flashing red, and the dialog window "Battery empty. Shutting down." appears.



During a call, only the corresponding battery warning signal will notify the user. The warning signal cannot be silenced during a call. When not in call, the warning signal can be silenced by pressing  or .

### Charge the Battery

Place the handset in the desktop charger or in the rack charger. The battery is being charged when the LED on the handset is steady orange. When the battery is fully charged the LED is green.

An animated battery icon  is also shown in the display indicating charging by starting with its current charge and ending with the full charge. A filled battery icon  indicates a fully charged battery.

**NOTE:** Only use the prescribed chargers for charging.

### Charge Spare Batteries

Spare batteries can be charged with a separate battery pack charger. It can charge six batteries at the same time.

**⚠ Important:**

It is not permitted to charge intrinsically safe batteries using the battery pack charger.

## Replace the Battery

If the standby time for the handset becomes too low, the battery should be replaced by a new one. Please contact your system administrator or your supplier, for information about new batteries. Attach the battery as described in [figure 13](#) on page 128. It is attached inside the battery lid and is connected to the handset in such a way that no misalignment of the contact is possible.

**NOTE:** Use the battery pack opener to untight the screws on the intrinsically safe handset.

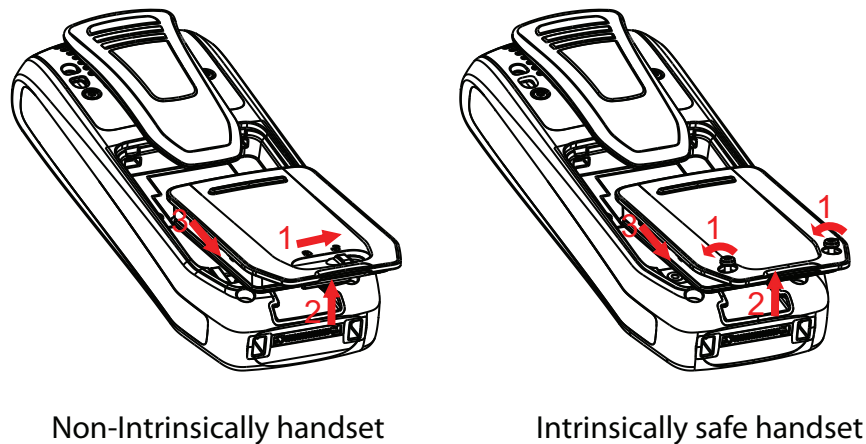


Figure 12. Replaceable battery. Unlock the lid, loosen the screws and remove the battery according to the illustration.

---

## Easy Replacement of Handset

Easy replacement can be used if a handset needs to be replaced due to, for example, a broken display. The easy replacement procedure is done via the handset display and the DC4 Advanced Desktop Charger, or the CR3 Charging Rack.

The following settings are replaced during easy replacement:


- DECT registration
- User parameters (including User ID)
- Contacts

- The extension number is assigned to the new handset.

The following settings are not replaced during the easy replacement:

- Call list
- Messages
- Bluetooth pairing list (3745/3749 only)

## Before Starting Easy Replacement Procedure

1. Check that both the old handset (that is, the handset to be replaced) and the new handset (that is, the replacement handset) are of the same device type (for example 3740).
2. Make sure that the handset batteries are charged before starting the easy replacement procedure.
3. Switch off the new handset by long pressing .

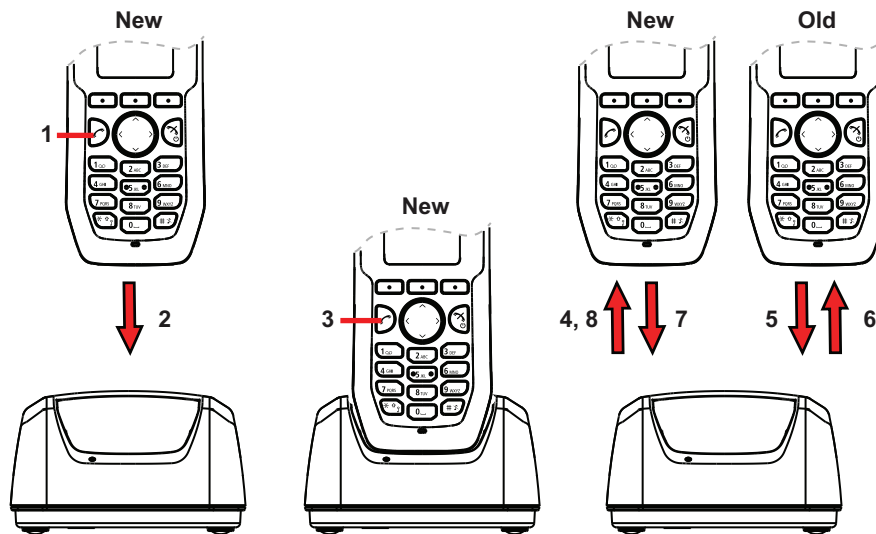
## Easy Replacement Procedure

During the Easy Replacement procedure, the LEDs of the handset and the charger follow the same LED indications. This means that if the old handset has a broken display, the LED indications on the charger and on the handset can be used to follow the replacement procedure. Before and after easy replacement, the LEDs may have different LED indications. For more details, see [LED Indications during Easy Replacement](#) on page 127.






### Important:

Never remove a handset from the charger until the instructions in the display or the LED tells you to do so (see status on the LED if the display is broken). If there is an error indication it may be allowed to remove the handset, see [Troubleshooting](#) on page 117 for further instructions. After the old handset has been in the charger, the new handset needs to be placed in the charger regardless if the replacement was successful or not. Failing to do so may result in malfunction and the new handset will need to be sent for service.



011

- 1 On the new handset, press and hold 
- Note: Do not release  until you are instructed to do so.
- 2 Put the new handset in the charger.
  - 3 When the text "Start phone replacement?" is displayed, release . Press "Yes" (left soft key). The text "Follow the instructions. Each step can take several minutes." appears in the display. Press "OK" (left soft key).

- 4, 5 When the text "Please insert old phone in charger" is displayed, replace the new handset with the old handset. The handset can either be switched on or off.

**Note:** If the CR3 Charging Rack is used, the left charging slot must be used for both handsets.

The handset is restarted and after a few seconds, the text "Saving settings. Do not remove phone from charger" appears. The charger LED changes to slow orange flashing. It may take several minutes.

 **Important:**

If the old handset cannot communicate with the charger, put the new handset in the charger to restore its settings (that is, the handset's IPDI). If this step is not performed, the new handset must be sent for service. The old handset's settings might be transferred to the new handset by using PDM/Device Manager. See the handset's Configuration Manual.

- 6, 7 When the text "Please insert new phone in charger" is displayed, replace the old handset with the new handset. The text "Restoring settings" is displayed.

 **Important:**

Do not remove the handset while the text "Restoring settings" is displayed

- 8 When the text "Phone successfully replaced. Please remove phone to restart." appears in the display, remove the handset from the charger. The handset is automatically restarted.

## LED Indications during Easy Replacement

The following table shows the LED indications that are used for the handset and the charger during the easy replacement procedure.

LED indication	Description
Orange, flashing (1 000 ms on, 1 000 ms off)	File transfer during Easy Replacement.
Orange, flashing (100 ms on, 800 ms off)	"Change phone" indication during Easy Replacement.
Red, flashing (100 ms on, 800 ms off)	Error indication during Easy Replacement. Put back new handset in charger.

Red, flashing (900 ms on, 100 ms off) Error during Easy Replacement. Service needed for both handsets.

---

## Attach the Hinge-type Clip

Attach the hinge-type belt clip as described in [figure 13](#).

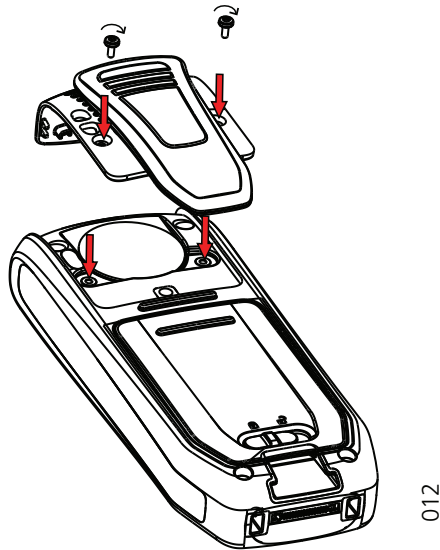


Figure 13. Screw the hinge-type clip into position.

---

## Attach the Swivel-type Clip

Attach the swivel-type belt clip as described in [figure 14](#).



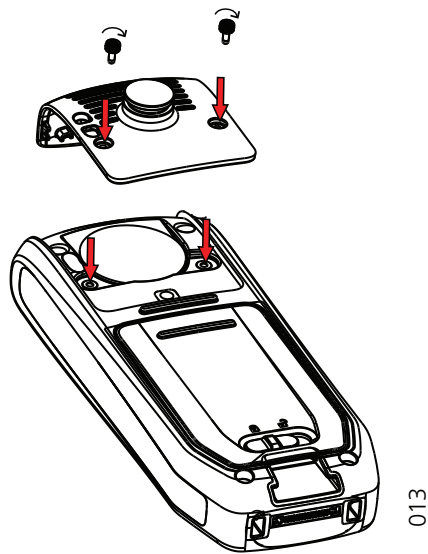


Figure 14. Screw the swivel-type clip into position.

---

## Attach Cover for No Clip

Attach the enclosed cover as described in [figure 15](#) when no clip is to be used.

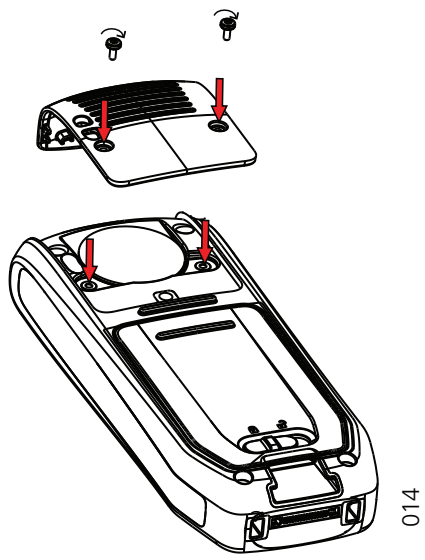


Figure 15. Screw the cover into position.

---

# Bluetooth Headset for 3745 and 3749 phones

---

## Introduction to Bluetooth

Bluetooth technology replaces the cord between the cordless telephone and the headset. This allows the user to move more freely and eliminates the risk of a headset cord getting stuck.

The Bluetooth is factory mounted on the cordless telephone's circuit board.

Bluetooth supported functions:

- Pair the cordless telephone with its headset
- Chose which device to use when making a call
- Play ring signal in the Bluetooth Headset
- Answer and connect sound to the Bluetooth Headset when answering with the headset's button.
- End call with the Bluetooth headset's button
- Transfer audio to/from Bluetooth headset during call, using the menu in the cordless telephone.
- Increase/decrease the volume in the Bluetooth headset with the volume buttons on the cordless telephone.

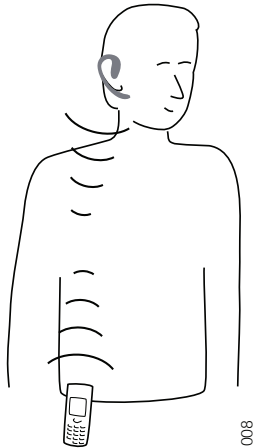
---

## Wear

For optimal performance wear the Bluetooth headset and the telephone on the same side of your body. The best audio quality in the headset is achieved when no obstructions, including your body, are between the headset and the cordless telephone.

---

**Figure 1: Wear the headset and the telephone on the same side of your body.**



---

## Headsets

A number of Bluetooth headsets for different work situations have been tested together with the telephone. Refer to the *Installation and Administration Manual, IP DECT* for a list of verified Bluetooth headsets.

Since the Bluetooth supports the Bluetooth 2.0 standard, other headsets may also work although not verified by Avaya.

**Note:**


Your Bluetooth headset may have more or less functions than described here, refer to the Manual for the Bluetooth headset.

---

## Operation

Step between the menus with the navigation key. Confirm each menu selection by pressing the Soft key **Select**.

### Enabling Bluetooth

1. Enter the menu by pressing the **Menu** Soft key, or the confirmation button on the navigation key.
2. Select **Connections** icon.
3. Select **Bluetooth**.
4. Select **Enable**. A Bluetooth connection icon  will be displayed in the header bar.

**Note:**

To disable Bluetooth again, select **Disable**. The 3749 cordless telephone restarts when you enable or disable the Bluetooth option.

## Pairing and connecting a Bluetooth headset

Before you can use a headset, you must establish a connection (pairing) between the headset and the telephone.

1. Place the Bluetooth headset and the telephone next to each other.
2. Select **Connections** icon in the telephone menu.
3. Select **Bluetooth > Headset > Add new**.
4. Put the headset in pairing mode and press the Soft key **OK**. The telephone starts to search for the headset.

**Note:**

For instruction, see headset manual.

5. The headset is displayed in the telephone menu **Headset found**. Press the Soft key **Select** on the telephone to select the headset. The pairing starts.
6. A PIN-code is requested for the Bluetooth headset. Enter the PIN-code and press **Select** on the telephone. **Pairing successful** is displayed.

**Note:**

For instruction, see headset manual.

7. The paired headset is displayed in the telephone menu **Headset**. When pairing a new headset it is automatically connected and will be used for calls.

## Adding another Bluetooth headset

You can configure up to four headsets to the telephone, but you can select only one at a time. To pair another headset repeat section "Pair and Connect a headset" steps 1-6.

The paired headsets are displayed by a default name in the telephone menu **Headset**. See 6. *Confirm with the Soft key Select.*

## Selecting a Bluetooth headset

1. Select **Connections** icon in the telephone menu.
2. Select **Bluetooth > Headset**.
3. Step with the navigation key, **▲** or **▼** to the headset to be selected.
4. Press the Soft key **Select**, **Connection successful** is displayed. The headset is now selected.

When a new headset has been selected any previous headset will automatically become disconnected.

## Removing a headset

1. Select **Connections** icon in the telephone menu.
2. Select **Bluetooth > Headset**.
3. Step with the navigation key, ▲ or ▼ to the headset to be removed.
4. Press the Soft key **More**.
5. Select **Delete**.
6. Confirm with the Soft key **Select**.

## Changing the name of Bluetooth headset.

The name, in the headset list, of the headset is the default name for the headset.

1. Select **Connections** icon in the telephone menu.
2. Select **Bluetooth > Headset**.
3. Step with the navigation key, ▲ or ▼, select the headset.
4. Select **More > Edit name**.
5. See [Alphanumeric keys](#) on page 37.

---

## Calling

### Making a call

1. Enter the number on the telephone.
2. Press the Soft key **Call** or the **Off-hook** key.
3. When **Transfer call to phone?** is displayed press **No** or ignore the message to use the Bluetooth Headset.
4. Press **Yes** to use the telephone.

### Answering a call

A ring signal sounds in both the selected Bluetooth headset and the telephone to signal an incoming call.

To answer the call in the Bluetooth headset, press the button\* on the headset.

To answer the call in the telephone press the **Off-hook** key on the telephone.

## Ending a call

Press the button\* on the headset or the **On-hook** key on the telephone.

---

## Volume/Mute Control

### Adjusting the volume during a call

Press the upper **Volume up** button on the upper left side of the telephone to increase the volume and the **Volume down** button to decrease the volume in the headset.

Depending on the Bluetooth headset it might be possible to adjust the volume directly on the headset\*.

### Turning the microphone On/Off during a call

Mute the headset and the telephone with the **Sound off** key on the telephone. See [Turning the telephone On/Off](#) on page 49.

---

## Messaging

When a text message is received during an ongoing call, a beep sounds in the Bluetooth headset.

---

## Transferring a call

### Transferring a call to the telephone

You are on a call with the Bluetooth Headset.

1. Press the Soft key **More** on the telephone.
2. Select **Audio transfer**.

### Transferring a call to the Bluetooth headset

You are on a call with the telephone.

1. Press the Soft key **More** on the telephone
2. Select **Audio transfer**.

It is also possible to transfer a call to the Bluetooth headset by pressing the button\* on the Bluetooth headset.

---

## Toggling to a headset with cord

If a headset with a cord is connected during a call, the call is transferred to this headset automatically.

---

## Menu Tree

See [Settings](#) on page 46.

---

## Operation Notice

### Accessibility and Voice quality

Bluetooth uses the frequency of 2.45 GHz. WLAN, microwave oven, and other devices that use the same frequency can disturb the use of a Bluetooth headset.

### Operation area

Maximum distance between the headset and the telephone is 10 metres. The communication distance between the telephone and headset may vary considerably due to the environment and disturbances from other 2.45 GHz equipment. Different headsets can also give different communication distances.

### Out of range

If a connection cannot be made with the selected Bluetooth headset the call is transferred automatically to the telephone.

If the Bluetooth headset and the telephone get out of range from each other the connection is temporarily lost. Since the last connected headset is always considered **selected**, the connection is automatically established again when a call is made or received.



---

## Environmental Requirements

### Bluetooth headset battery

See the manual for the Bluetooth headset.

---

## Troubleshooting

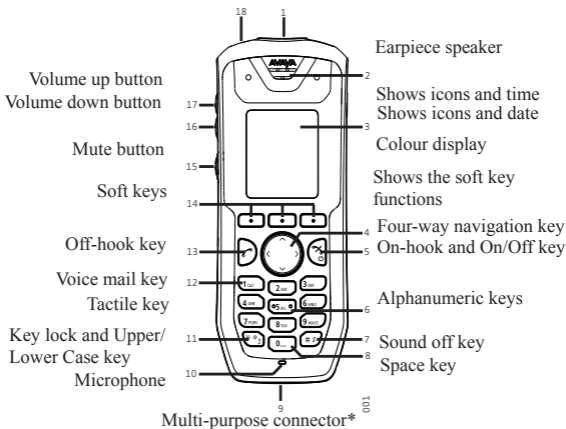
Problem	Reason	Solution
No headset found	Headset is turned off	Turn on headset
	Headset is out of battery	Charge headset
	Headset is out of range	Move headset closer to telephone < 10 meter.
	Headset is not in pairing mode	Turn headset into pairing mode (see headset manual for details)
Pairing fails	Headset is not in pairing mode	Turn headset into pairing/discoverable mode (see headset manual for details)
	Incorrect PIN entered	Try again and enter correct PIN (see headset manual for details)
Connecting fails/Failed to connect headset	Headset is not turned on	Turn on headset
	Headset is out of range	Move headset closer to telephone
	Link key in headset has been deleted	Repeat pairing procedure
	Headset is already connected to another telephone	Disconnect headset from the other telephone
	Too close to disturbing devices.	Disturbing devices can be WLAN equipment, microwave etc.
Headset can not connect to telephone (see headset manual for details on how to connect)	Telephone is not turned on	Turn on telephone

<b>Problem</b>	<b>Reason</b>	<b>Solution</b>
	Telephone is out of range	Move telephone closer to headset
	Bluetooth module is disabled	Enable Bluetooth in Bluetooth menu
	Another headset is already connected to the telephone	Disconnect the connected headset
	Link key is missing in either headset or telephone.	Repeat pairing procedure
	Too close to disturbing devices.	Disturbing devices can be WLAN equipment, microwave etc.




























































Avaya 374x DECT  
Telephones  
Quick Reference Guide

## LED Multifunction/Alarm button



*\*)Used for battery charging, software download, configuration and connection of headsets.*

3749	3745	3740	Display Icons
			Signal strength
			Battery status
			Voice mail
			Sound off
			Ring volume set to silent
			Loudspeaker on
			Loudspeaker off
			Microphone off
			Headset connected
			Bluetooth headset connected (only for 3745 and 3749)
			Bluetooth (only for 3745 and 3749)
			Man-down alarm (only for 3749)
			No-movement alarm (only for 3749)
			New message
			Read message
			Missed call
			Incoming call
			Outgoing call
			System connection
			Key lock
			Phone lock

## Product presentation

The cordless telephone is a feature-rich handset with colour display, telephony, messaging, and bluetooth. It is designed to be used in office environment and medium demanding environment such as hospital environment.

It is suitable for users dependent of being reachable and/or having a need for mobile voice and messaging features, which makes it ideal for applications where the user needs either one way messaging or to be able to interact with other users. The colour display enhances and simplifies the use of the cordless telephone.

Read the safety instructions before use.

For software download and parameter set up, read the *Installation and Administration Manual, IP DECT*


<i>Functions</i>	<i>374x</i>
<i>Local phonebook (250 contacts)</i>	<i>X</i>
<i>Central phonebook</i>	<i>X*</i>
<i>Company phonebook</i>	<i>X</i>
<i>Vibrator</i>	<i>X</i>
<i>Headset connector</i>	<i>X</i>
<i>Microphone on/off during call</i>	<i>X</i>
<i>Loudspeaking function</i>	<i>X</i>
<i>SMS (Short Message Service)</i>	<i>X*</i>
<i>Voice mail access</i>	<i>X*</i>
<i>Centralized management</i>	<i>X*</i>
<i>Procedure call</i>	<i>X</i>
<i>Telephone restrictions</i>	<i>X</i>
<i>Easy replaceable battery (for 3740 and 3745 telephones only)</i>	<i>X</i>
<i>Bluetooth (for 3745 and 3749 telephones only)</i>	<i>X</i>

*\* System dependent*

Note: Your unit may have more functions than described here; see *User Guide, Avaya 374x DECT Telephones*.

## Basic functions

### Switch the telephone on/off

Press and hold the **On-Hook** key  until pop-up question is displayed.


### Make a call

Dialling can be made in the following ways:

- In idle screen, dial the number and press the **Off-hook**

key .

- Press the **Off-hook** key  and enter the number.
- Press a pre-programmed Hot key\* or Soft key.
- Dial a number from the local phonebook. Enter the Contacts menu, select **Call contact** and select the name


from the list, press **Call** or the **Off-hook** key .


- Dial a number from the Central phonebook. Enter the Contacts menu, select **Central phonebook > search by name/number/last result**, and press **Search**. Press **Off-**

**hook** key .

\* *The alpha-numeric keys can be programmed with a telephone number.*

### Answer/End a call


When the ring signal sounds; press the **Off-hook** key  to answer.

To end the call, press the **On-hook** key .

### Turn loudspeaking function on/off



During a call, press the left Soft key to turn the loudspeaking function on/off.

### Turn audio signals on/off

In idle mode a long press on the **Sound off** key changes between audio signals on/off. The **Sound off** icon  indicates a completely silenced telephone.

- A short press on the **Sound off** key before answering a call, silences the ring signal.


### Lock/Unlock the keypad manually

Press the -key to lock/unlock and then Soft key **Lock/Yes**. The **Locked keypad** icon  indicates a locked keypad.

### Change the volume during a call

Press the Volume button upwards to increase the volume, downwards to decrease the volume. Or, use the Navigation key to adjust the volume.

### Charge the battery

Charging is done in a desktop charger or in a charging rack. Charging is indicated by orange LED. When the battery is fully charged the LED is green and a fully charged **Battery** icon  is displayed.

While in a desktop charger the telephone is fully operational. The telephone does not vibrate in charger.

The battery can also be charged in a separate battery pack charger.

**Note:** Charging below 5°C will harm the battery and shorten the lifetime.

### Remove the battery


It is recommended to switch off the telephone before removing the battery.

## Messaging

### Receive a text message

When a text message is received, the LED starts flashing and a message tone sounds. A pop-up **New message(s):1 View now?** is displayed and the Soft keys **Yes/No** to read




the message now or later. The message is then stored in the message list. The **New message** icon  is shown in the display.

If the message is received during a call, the user is notified by a beep.

### Read a stored message

Open the Message list, either from the messaging menu or by pressing the Navigation key in Idle screen. Use the Navigation key to navigate in the Message list. Select message and press the soft key **View** to read the message.

### Send message

Open the Messaging menu , and select **Write new message**. Enter text, press the soft key **Send**, and then enter a number, or press the middle soft key for phonebook look-up. Press **Send**.

Delete a stored message

To delete a message, select message and press the soft key **More**, select **Delete**, and press the soft key **Yes**.

Check voice mail

A new voice mail is indicated in the display by the text **MW**. Only one voice mail at the time will be displayed in the message list.

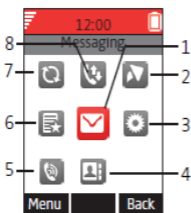
Open the **Messaging** menu, select **Message list** select **MW-Consult**.

or

A long press on digit key **1** will call your voice mail. If the extension number is not available a pop-up **Voice mail number not defined** is displayed. See *User Guide, Avaya 374x DECT Telephones*.

## Menu

For 3740 DECT telephones, the display is monochrome, black and white. *For descriptions of all functions; see User Manual, Cordless Telephone 374x.*



#### Figure notes:


- |              |                  |
|--------------|------------------|
| 1. Messaging | 5. Profiles      |
| 2. Shortcuts | 6. My favourites |
| 3. Settings  | 7. Connections   |
| 4. Contacts  | 8. Calls         |

#### Navigate the menu

Use the Navigation key to move around in the menu structure.

The three Soft keys below the display are used for choices in the menu. The function of each Soft key is explained by text in the soft key field in the display.

#### Use the local phonebook


To find and call a name: Enter **Contacts** , step to **Call contact** and press **Select**. Enter the first letter in the name or the whole name (will be displayed in Search field while entering text), or step in the contact list. Select the name and press **Call**.

To edit the contact: Select **Edit contact**, select the name and press **Edit**. Make your changes, press **OK** and then press **Save**.

To add a contact, select **Add contact**, select **New** or **From call list**. Press **Add**, enter the name and press **OK**. Select **Number**, enter the number, press **OK** and press **Save**.

To delete a contact: select **Delete contact**, select the name, press **Delete**, and then press **Yes**.

### Use the central phonebook

Enter **Contacts** , and select **Central phonebook**. Select **Search by name**, **Search by number**, or **Last result**. Enter the first letter(s) in the first name, and/or the first letter(s) in the family name. Press **Search**. The Central phonebook will be searched and a list of matching names will be displayed. You can step to the next entry in alphabetic order by pressing the Navigation key. Press **More** to add contact, or press **Call** to make the call.

### Use the company phonebook

The company phonebook has to be imported via the PDM before it will be visible in the handset. See *User Manual, Cordless Telephone 374x*.

Enter **Call list**. Select name/number and press **Call**, only work number is available for the contact and it is not editable.



### Soft keys, Hot keys and Multifunction button

The three Soft keys below the display can be defined for specific functions such as dialling a specific number.

A long press on a Hot key can have the same function as a Soft key and any key **0**, **2 - 9** can be programmed as a Hot key. The Multifunction button can also be programmed for different functions with the use of long press and double press.

For more information about Soft keys, Hot keys and Multifunction button, see *User Guide, Avaya 374x DECT Telephones*.

## Turn the automatic keypad lock on/off

Enter **Settings** , and step to **Locks**. Select **Automatic key lock Off/On**, select **On/Off**, and press **Back**. A locked keypad is indicated by the **Key lock** icon .

To unlock, press the key , and then the Soft key **Yes**.

## Accessories

The following accessories for the Avaya 374x DECT telephone are available:



Leather casing incl. belt clip    Belt clip, swivel type



Desktop chargers

### **Also available:**

- Rackmount Charger
- Multiple Battery Charger for 3740 and 3745 DECT telephones
- Headset Mic on boom
- Peltor hearing protection headset

# Index

## A

Accessories . . . . .	<a href="#">38</a>
Admin Menu . . . . .	<a href="#">109</a>
Alarm Operations for 3749 telephones . . . . .	<a href="#">100</a>
Alphanumeric keys . . . . .	<a href="#">37</a>
Antenna . . . . .	<a href="#">30</a>

## B

Battery . . . . .	<a href="#">31</a> , <a href="#">124</a>
low battery . . . . .	<a href="#">34</a> , <a href="#">124</a>
Belt Clips . . . . .	<a href="#">38</a>
Bluetooth headset . . . . .	<a href="#">131</a>
calling . . . . .	<a href="#">134</a>
enable . . . . .	<a href="#">132</a>
pairing . . . . .	<a href="#">133</a>
verified types . . . . .	<a href="#">132</a>

## C

Call answering . . . . .	<a href="#">54</a>
Call declining . . . . .	<a href="#">54</a>
Call diversion . . . . .	<a href="#">72</a>
Call info . . . . .	<a href="#">36</a> , <a href="#">40</a>
call priority . . . . .	<a href="#">111</a>
Call service . . . . .	<a href="#">36</a>
Call Services . . . . .	<a href="#">71</a>
Call Waiting . . . . .	<a href="#">60</a>
Calling	
answered call . . . . .	<a href="#">35</a>
call a number from the call list . . . . .	<a href="#">54</a>
dial a number . . . . .	<a href="#">55</a>
missed call . . . . .	<a href="#">35</a>
outgoing call . . . . .	<a href="#">35</a>
quick call by a name in the phonebook . . . . .	<a href="#">56</a>
Calls	
menu tree . . . . .	<a href="#">40</a>
Case . . . . .	<a href="#">30</a>
Central phonebook . . . . .	<a href="#">73</a>
Charger . . . . .	<a href="#">31</a>
disconnect telephone . . . . .	<a href="#">32</a>
Chemical resistance . . . . .	<a href="#">21</a>
Clip . . . . .	<a href="#">30</a>
Company phonebook . . . . .	<a href="#">73</a>
Conference Call . . . . .	<a href="#">60</a>
Connections	

menu tree . . . . .	<a href="#">45</a>
Contacts	
menu tree . . . . .	<a href="#">41</a>

## D

Dialing a name from the central phonebook . . . . .	<a href="#">56</a> , <a href="#">57</a>
Dialling	
International number . . . . .	<a href="#">55</a>
Dispose of old equipment . . . . .	<a href="#">15</a>
Divert Calls . . . . .	<a href="#">72</a>
DTMF . . . . .	<a href="#">62</a>

## E

Earpiece . . . . .	<a href="#">30</a>
Easy replacement of handset . . . . .	<a href="#">124</a>
Emergency Calls	
Keypad lock . . . . .	<a href="#">92</a>

## F

Favourites . . . . .	<a href="#">86</a>
menu tree . . . . .	<a href="#">44</a>
Frequency range . . . . .	<a href="#">17</a>
Functions and accessories . . . . .	<a href="#">24</a>

## H

Handsfree key . . . . .	<a href="#">28</a>
Headset connector . . . . .	<a href="#">28</a>
Hot keys . . . . .	<a href="#">37</a>

## I

Icons . . . . .	<a href="#">34</a>
Idle mode	
date . . . . .	<a href="#">33</a>
time . . . . .	<a href="#">33</a>
user identity . . . . .	<a href="#">33</a>
In Call	
menu tree . . . . .	<a href="#">47</a>

## L

LED indications . . . . .	<a href="#">127</a>
Lock/unlock	

keypad . . . . .	<a href="#">51</a>
telephone . . . . .	<a href="#">52</a>
Loudspeaker . . . . .	<a href="#">30</a>
Loudspeaking . . . . .	<a href="#">34, 54</a>

---

## M

Message	
new message . . . . .	<a href="#">34, 78, 79</a>
old message . . . . .	<a href="#">34</a>
send . . . . .	<a href="#">64</a>
template	
answer text message . . . . .	<a href="#">114</a>
voice message . . . . .	<a href="#">34</a>
Message Indication Repetition . . . . .	<a href="#">111</a>
Message volume. . . . .	<a href="#">91</a>
Messaging	
menu tree . . . . .	<a href="#">43</a>
Microphone . . . . .	<a href="#">30</a>
on/off . . . . .	<a href="#">58</a>
Missed calls list . . . . .	<a href="#">68</a>
Multifunction Button . . . . .	<a href="#">37</a>
Mute button . . . . .	<a href="#">37</a>
Muting ringtone . . . . .	<a href="#">53</a>

---

## N

Number input mode . . . . .	<a href="#">38</a>
-----------------------------	--------------------

---

## O

Operating area . . . . .	<a href="#">122</a>
Out of Coverage . . . . .	<a href="#">122</a>
Out of coverage . . . . .	<a href="#">122</a>

---

## P

Personal phonebook . . . . .	<a href="#">73</a>
PIN code . . . . .	<a href="#">53, 94</a>
Procedure Call. . . . .	<a href="#">109</a>
PTT. . . . .	<a href="#">69</a>
PTT- Accepting an invitation . . . . .	<a href="#">69</a>
PTT- rejoining a group . . . . .	<a href="#">71</a>
PTT, Accepting a call . . . . .	<a href="#">69</a>
PTT, calling a group . . . . .	<a href="#">70</a>

---

## Q

Quick Reference Guide . . . . .	<a href="#">139</a>
---------------------------------	---------------------

---

## R

Ring signal muted . . . . .	<a href="#">34</a>
-----------------------------	--------------------

---

## S

Safety Information . . . . .	<a href="#">11</a>
Screen Saver	
settings . . . . .	<a href="#">95</a>
Setting a ring signal for a contact . . . . .	<a href="#">90</a>
Settings . . . . .	<a href="#">107</a>
menu tree. . . . .	<a href="#">46</a>
Shared phone . . . . .	<a href="#">49</a>
Short cuts	
menu tree. . . . .	<a href="#">44</a>
Signal strength . . . . .	<a href="#">34</a>
Sound off button . . . . .	<a href="#">37</a>
Special characters . . . . .	<a href="#">64, 82</a>
Switch between Calls . . . . .	<a href="#">59</a>
Switch telephone on/off . . . . .	<a href="#">49</a>

---

## T

Text input mode . . . . .	<a href="#">38</a>
Transfer Call . . . . .	<a href="#">60</a>
Troubleshooting . . . . .	<a href="#">117</a>
Bluetooth . . . . .	<a href="#">137</a>

---

## V

Voice mail . . . . .	<a href="#">65</a>
Voice quality . . . . .	<a href="#">122</a>
Volume	
adjust during a call . . . . .	<a href="#">57</a>
button . . . . .	<a href="#">37</a>

---

## W

Writing Text and Numbers	
pause. . . . .	<a href="#">38</a>
upper and lower case . . . . .	<a href="#">38</a>
Writing Text/Numbers	
add space in text . . . . .	<a href="#">38</a>